

# THE OCCULT REVIEW

A MONTHLY MAGAZINE DEVOTED TO THE INVESTIGATION OF SUPER-NORMAL PHENOMENA AND THE STUDY OF PSYCHOLOGICAL PROBLEMS

EDITED BY RALPH SHIRLEY

Price SIXPENCE; post free, SEVENPENCE. Annual Subscription, SEVEN SHILLINGS. Abroad, EIGHT SHILLINGS (Two Dollars),

*Entered at Stationers' Hall.*

LIVERPOOL OFFICE: Office of the *Timber Trades Journal*, Liverpool and London Chambers, Dale Street, Liverpool.

AMERICAN HEAD OFFICE: 669, Sedgwick Street, Chicago. Agents, The *American News Company*, New York; The *New England News Company*, Boston; the *Western News Company*, Chicago.

All communications to the Editor should be addressed c/o the Publishers, WILLIAM RIDER & SON, LIMITED, 164 Aldersgate Street, London, E.C.

SUBSCRIPTIONS can be sent either to the London Office, or to 669, Sedgwick Street, Chicago.

---

VOL. IV.

AUGUST 1906

No. 8

---

## NOTES OF THE MONTH

THE present issue of the OCCULT REVIEW consists, like its predecessor, of sixty-four pages instead of fifty-six, the demands on the Editor's space becoming every month more urgent, and much matter having been unavoidably held over in consequence.

A postponement of the award of the £5 prize for the best TO "OCCULT  
REVIEW"  
READERS. authenticated record of the appearance of an animal in visible form after death is, I am sorry to say, inevitable, in view of the necessity of the earlier appearance of the magazine to meet the

American demand. This award will duly appear in the September issue, when the subject of a new competition will be announced. The notice of the OCCULT REVIEW Psychometrist appears this month on page 120, to which I would refer readers who wish to send up coupons for diagnosis.

In his *Enigmas of Psychical Research* Professor Hyslop quotes, from a letter which originally appeared in the *Spectator* under the signature of Mrs. Caroline Barber, a very interesting experience, which I repeat in this place, because it illustrates the transfer of thought from mind to mind in its simplest and most natural form, and

TELEPATHIC  
RECORDS.

also because I am in a position to cap the experience with several parallel records that are very similar in their character.

Mrs. Barber wrote—

I had one day been spending the morning shopping, and returned by train just in time to sit down with my children to our early family dinner. My youngest child—a sensitive, quick-witted little maiden of two years and six weeks old—was one of the circle. Dinner had just commenced, when I suddenly recollected an incident in my morning's experience which I had intended to tell her, and I looked at the child with the full intention of saying, "Mother saw a big black dog in a shop, with curly hair," catching her eyes in mine as I paused an instant before speaking. Just then something called off my attention, *and the sentence was not uttered*. What was my amazement, about two minutes afterwards, to hear my little lady announce, "Mother saw a big dog in a shop." I gasped, "Yes, I did!" I answered; "but how did you know?" "With funny hair," she added quite calmly, and ignoring my question. "What colour was it, Evelyn?" said one of her elder brothers; "was it black?" She said, "Yes."

Now, it was simply impossible that she should have received any hint of the incident verbally. I had had no friend with me when I had seen the dog. All the children had been at home in our house in the country, four miles from town; I had returned, as I said, just in time for the children's dinner, and I had not even remembered the circumstance until the moment when I fixed my eyes upon my little daughter's.

A lady who has written more than once in the pages of the OCCULT REVIEW told me that on one occasion while occupied in writing a play, her little girl being with her in the room at the time, she was endeavouring to picture to herself a scene in which a man was being hypnotized to death by being made to imagine that he was being crushed by a python which was coiling itself round him. Suddenly the child looked up and asked, "Mummy, how does a snake crush a man to death?" no word having passed between them. It is noteworthy that the same child had a premonition of her dog being run over and killed by a motor car, and this subsequently happened.

I have myself, on several occasions, mentally anticipated the words which were about to be spoken to me by the person with whom I was in conversation, and other people have told me that they have had similar experiences. On one occasion I was walking out with a young friend who had a little sister of six or seven years of age. My friend stammered, but before he uttered a word I knew he was going to say, "Have you heard that Katie has had a little girl?" Katie being his

TRANSFER OF  
MENTAL  
PICTURE.

WORD  
TRANSFERENCE  
WITHOUT  
IDEA.

little sister, his stammering gave me time to reflect "What a ridiculous thing for him to be going to say!" when he came out with the sentence, "Have you heard that \*Katie has had a little girl in to tea with her?" adding further details which I do not now recollect. The words that were used were word for word in their order those which I had in my mind, only my subconscious brain failed to transfer them to the point at which their meaning would have become clear to my normal consciousness. I had no reason to anticipate any remark from my friend on the subject of his little sister. This incident seems to me noteworthy as serving to show that sound as well as sense can be transferred from mind to mind, and that it is not merely the idea—sometimes not the idea at all—that the receiving (brain) instrument records. Confirmatory of this is a question once put to her mother by my contributor's little girl (above referred to), "Mummy, what are eternal verities?" The mother had just been mentally framing a sentence in which the words occurred which, of course, had no meaning whatever to the child.

It would be a matter of interest to collect statistics on the comparative psychical susceptibility of children. Apparently in most cases this psychical susceptibility is a phase rendered possible by certain physical conditions, which quite passes away before maturity. It is, in fact, outgrown, and

CHILDREN	children "seers" seldom grow up into "psychics."
PSYCHICS.	A relative of mine, long since grown up, sends me a record of her only experience as a clairvoyante which occurred when she was four years of age, and may not inappropriately be quoted here. She writes:—

At between four and five years of age, I was taken by my mother to visit one of her great-aunts in a country house. We arrived late at night, and I was carried straight upstairs from the "fly" to the bedroom I was to occupy with my mother, and put to bed. When my mother came upstairs, I awoke, sat up in bed, and chattered to her. I then suddenly startled her, by asking who that funny old man was, who had just entered the room? She said, "There is no one"; and then on my being so persistent and fearing to frighten me, she asked what he was like, and what he was doing, and finally pretended she saw him. I described him as wearing what seemed to me a most peculiar dress. He was walking about the room, and finally stopped in front of an old bureau, and appeared to be trying to open it. My mother the whole time could see nothing. On his disappearing, she said it was of no consequence, and told me to go to sleep. The next morning we went down to the breakfast-room, where I immediately discovered a picture, to which I pointed, exclaiming, "That

---

\* The name is intentionally altered.

is the old man who came into our room last night." The old aunt was not present, and I had never seen her ; but on her elderly maid coming into the room to serve our breakfast, my mother asked her who the picture represented. The maid said it was the portrait of her great-aunt's husband, and on further questioning, it appeared he had died exactly a year before, and in the very room we had occupied. He was a Quaker, and always wore the dress. I may mention that I had been out of England for two years with my parents, and had never heard of the sect.  
—L. E. MARSHALL SMITH.

What should they know of England who only England know ? asks one of our Sunday papers with wearisome iteration regularly once a week. What should they know of Psychological Research, we may ask with equal if not greater pertinence, who have no knowledge of other branches of Occult Science ?

I cannot but regard the discovery of the association of the  
 NEPTUNE'S planet Neptune with psychical tendencies on  
 DUAL the one hand and (in cases where it afflicts the  
 CHARACTER. horoscope financially) with fraud and bogus  
 enterprises on the other as being perhaps the  
 most remarkable and suggestive result of astrological investigation during the last ten or fifteen years. Working on totally different lines and from a totally different standpoint, the investigators of the phenomena of mediumship are gradually arriving at a conclusion on which this discovery may eventually through a flood of light. The exposures of Craddock and Eldred have "given furiously to think" alike in "metapsychical" and spiritualistic circles, and two or three recent articles in *The Annals of Psychological Science* are straws showing which way the wind blows.

It is practically maintained in one of these that fraud is an  
 MEDIUMSHIP accompaniment of all *professional* mediumship,  
 AND FRAUD. and that it is almost inevitable, in the case of  
 mediums who hold séances constantly. The  
 writer scouts the usual explanation that the medium is guilty of deliberate fraud so that he may not disappoint his audience when he finds himself unable to go into a trance at the required moment, and suggests instead hypnotic conditions as the result of over-frequent mediumship.

With due deference to the writer, I think we need make no bones about saying that fraud pure and simple under conditions which make detection difficult and before uncritical audiences will take us a very long way towards the explanation of many marvels of the séance room. At the same time, it is difficult to conceive that a *genuine* medium would *readily* resort to fraud,

and that *all* genuine professional mediums sooner or later have recourse to fraudulent methods is hard to believe, unless there is something more in the matter than meets the eye. Personally, I am convinced that constant mediumship tends inevitably to loss of self-control and even to the ultimate dissolution of the individuality. You cannot let your body be played with by a long succession of undesirable entities of doubtful character without ceasing yourself to become its master. You cannot lease your mortal tenement and retain full rights of re-entry.

The only occasion on which I ever saw Craddock was a number of years ago now, and perhaps in those days he was less given to fraudulent practices. At least, I took the opportunity the instant the séance was over of going up to the cabinet and seeing the medium for myself. I may safely say that I never saw a more pitiable wreck of humanity in all my life. The medium was in a state of the most abject hopeless collapse, and it was with some little difficulty that he could even be lifted into a chair to partially recover himself. Eventually, he was half dragged, half carried out of the séance room. I made a mental note at the time that, if he went on at this sort of game, holding séances two and three times a week, he would be a dead man in six months. And so I daresay he would. But what are we to say of the people who leave a medium the option of physical ruin on the one hand or fraud on the other? Is it the medium we ought to blame?

THE SEAMY  
SIDE OF  
SÉANCES.

## RECENT RESEARCHES IN FRANCE

By H. A. DALLAS

BEFORE I embark on the task I have set myself, which is indicated in the heading of this article, I wish to call attention to an essay by the late F. W. H. Myers, published as far back as 1888, and called, "The Disenchantment of France." \* It shows an almost prophetic insight into the trend of the psychological development of the French nation, into the principles then at work, and the direction in which renewal might be expected. In this article he indicated very clearly what he believed to be a process of disintegration then going on in France, the effects of which were apparent in quenched hopes, and the drying up of the springs of life. He quotes a passage from the writings of M. Bourget, which shows how observant Frenchmen recognized at that time the fact of this disintegration. From this quotation I will cull two sentences.

"It is probable that in the final bankruptcy of hope to which science is leading us, many of these souls will sink into a despair such as Pascal would have sunk into had he lost his faith. . . . Life will be unbearable with the knowledge that there is no more hope of understanding it; and that the same sign of fruitless question hangs ever over the horizon of man."

Mr. Myers proceeds to show that what he calls "the disenchantment of France" had robbed her of four vitally important beliefs; belief, (1st) in the moral government of the world (the religious illusion); (2ndly) in the worth of human fellowship (the political illusion); (3rdly) in the worth of human love (the sex illusion); (4thly) in free-will and psychical unity (the personal illusion); and that the loss of these "illusions" was sapping the national vitality. For religion, politics, marriage, and personal character were deprived, by this loss, of significance and sanctity.

If it is conceivable that some nations could survive such a denudation and preserve their corporate integrity, it is not conceivable that France could do so. For the French are largely

\* Published subsequently in a volume called *Science and a Future Life*. Putnam's Sons.

a Celtic race, and if the Celtic element is starved out of them, what remains ?

The Celtic element involves both belief in a supersensible world, and the emotion of national enthusiasm ; romance in love, and hero-worship (i.e. appreciation of individual worth) are also integral parts of the Celtic character. France cannot be denuded of these elements without losing the essential constituents of her race. If the disillusionment of France were to be consummated, the nation would be lost to Europe. She would no doubt dwindle slowly, but the final conclusion would be but a matter of time.

Even so far back as 1888, however, Mr. Myers was far from accepting such a catastrophe as inevitable or even probable ; he detected a way of escape. He saw tokens of re-awakening and of the re-birth of hope ; and he believed that the constructive forces would come into play along the same lines by which the destructive forces had worked, that is to say, through scientific investigations. The spiritual revival which he anticipated would, he thought, start from a scientific rather than an emotional basis.

Now that we are removed by seventeen or eighteen years from the time when these ideas were expressed, we may ask how far events have justified them. Not perhaps altogether. There are renewing forces now actively operative in France which are more of the emotional than of the scientific type. The inspiring energy of the association known as "L'Union pour l'action morale," has done much to quicken into activity latent enthusiasms for righteousness ; the work of the Union springs from elements in human nature profounder than the scientific. To some extent, however, Mr. Myers' forecast has been justified ; and the facts support his contention, that no beliefs can permanently win the adherence of the French nation which cannot show themselves solidly grounded on a basis which satisfies the reasoning faculties of the brilliant and acute French intellect.

Mr. Myers is surely right when he conceives a Frenchman as saying, "I cannot respond to stimuli addressed to my emotions alone. . . . I see little reason to suppose that we survive death, or that life has a moral meaning. . . . At the same time, I am quite aware that we are still at the beginning of our scientific knowledge of the universe and of man. It is possible that you may discover something which will change my attitude."

This brings us to the subject of this article. For the recent researches which scientific students have been conducting in

France force upon us the question, Are there reasons for believing that this "something" is either on the verge of being discovered, or even has already been discovered? If so, although that "something" be but "a little cloud no bigger than a man's hand," it is surely destined to effect very important and far-reaching changes in the psychological outlook and ethical beliefs, not of France alone, but of the whole civilized world; since (and this Mr. Myers recognized) the tides that wash the promontories of French thought will sooner or later reach the shores of other nations also. I wish to show that there are very good reasons for answering the above question in the affirmative; but in support of this statement I cannot, of course, avail myself of more than a fragment of the material which exists. I shall restrict myself to briefly noticing the work of two distinguished Frenchmen, omitting, for lack of space, all reference to that of other careful and able students in this field of research. These two are Professor Richet and Dr. Maxwell.

Since, however, large demands on credulity have often been made on insufficient testimony, alike in the domain of theology and of occultism, and of science, I must begin by stating the grounds on which it may be claimed that Professor Richet and Dr. Maxwell are typical instances of French intelligence, and therefore that, on this account, their attitude towards Psychical Research may fairly be regarded as an indication of a changed attitude in the French nation, and one which may prelude the light of a new dawn and result in the revival of those Celtic elements so vital to her well being.

Professor Charles Richet, besides being a member of the Academy of Medicine in Paris, and Professor of Physiology, holds the degree of honorary membership for life in the Academy of Rome, an honour awarded to few, and he is also member of the Academies of Medicine at Brussels, Dublin and Toronto. In 1903-4 he received the prize for Physiology, which is bestowed every seven years by the Academy of Science in Paris. In medicine he has made discoveries for the cure of disease which are widely accepted as allaying its ravages. As an author he is more especially known as the composer of a huge Dictionary of Physiology which has now reached its seventh volume.

These details show that intellectually and scientifically he is well equipped for investigation; but, in addition, he has certain special qualifications for dealing with the intricate problems involved in Psychical Research.



Thirty years ago he discovered in himself considerable power of magnetism, and although this subject was then forbidden by the Faculty, the Professor pursued the study of somnambulism, magnetism, and hypnotism with diligence, and notwithstanding the opposition of the whole medical profession, he published a résumé of his experiments and observations in 1875 in a medical review (*Anatomy*) and again in 1881 in *La Revue Philosophique*. By his experiments he demonstrated before the Academy of Paris that the magnetic sleep was an actuality. He studied carefully the "changes of personality" under the effect of the magnetic sleep. These studies he pursued for three years in the face of official opposition. Subsequently the scientific world was compelled to acknowledge the legitimacy of the study, and Charcot, Liébault and others have, as is well known, gained their celebrity by following in the track which Professor Richet's persistent inquiries had made. He has continued to watch closely and to keep himself thoroughly informed of the work which has been carried on in the field of psychical investigation by his friend, the late Mr. F. W. H. Myers, and others in England and elsewhere. But until the year 1905 he has published little or nothing on the subject. With keen observation he combines extreme caution, and is on his guard to avoid publishing anything that future research may disallow. When we add to these qualifications as a researcher the fact that he possesses in full measure the scientific virtue of persistent patience, it is obvious that he is a man eminently fitted to explore these little known and perplexing regions open to human understanding.

Quite recently Professor Richet has expressed himself several times in connexion with this subject. And, whilst his attitude is still non-committal, he has taken a step of great importance in advance of that taken by the majority of those who reject the hypothesis of the intervention of discarnate beings.

He has deliberately stated in his address before the Society for Psychical Research, that although he does not accept that hypothesis, neither does he accept any other as sufficient to explain all the facts. He affirms that the various theories advanced by students to account for the facts do not account for *all* of them, that there are occurrences of an intelligent character, which remain unexplained by the various theories of subliminal consciousness, telepathy, etc., which have hitherto been applied to them. It is therefore patent that the scientific world in France is beginning to own that there are facts verifiable and verified, which bear a character of being intelligently originated, which

none of the orthodox hypotheses of science are adequate to explain.

Professor Richet and the French researchers generally have not gone so far as to admit that survival is *proved* by the facts they have verified, but they have gone quite far enough to enable a watchful student of events to recognize that the "little cloud" is already gaining in volume, and for prophetic ears to hear the sound of "abundance of rain."

In his article in the first number of the *Annals of Psychological Science*, Professor Richet says, "Instead of seeming to ignore spiritism, scientists should study it. . . . If there are many errors and illusions in the assertions of spiritists, there are probably—nay, certainly—many truths, truths which for us are still enveloped in mystery. These truths, when they are better understood, will profoundly modify the puny notions we at present entertain concerning man and the universe."\*

The self-expression which the cautious Professor has now allowed himself is probably due to the recent experiences which he has had through a lady whom he calls Mme. X. This lady was introduced to him about six years ago by Mr. F. W. H. Myers, and from that time to the present he has had frequent phenomena under observation in connexion with her. For a detailed account of these experiences readers should refer to Dr. Maxwell's recent book *Metapsychical Phenomena*, and to an article called "Xenoglossy, or automatic writing in foreign languages," in the June number of *The Annals of Psychological Science*. I must confine myself to making one citation only from these remarkable occurrences.

Mme. X. is a lady of culture, whose psychic gifts are used solely with a view to further the discovery of truth. Her balanced and intelligent mind is often exercised in forming a critical estimate of the value of the strange things which occur in her presence or through her faculties. At the time when the experience happened to which I am about briefly to refer, *i.e.* in 1900, Professor Richet knew her very slightly, and he affirms that his friend, "Antoine B.," who is concerned in it, had never been mentioned in her presence. "I can certify," he says, "that the name of Antoine B. had not been pronounced in her presence up to the month of October, 1900."

Nevertheless, in the beginning of October, 1900, he received from Mme. X. a letter stating that on October 1st, when she was

\* *Annals of Psychological Science*, January, 1905, p. 46.

travelling from Paris to Fontainebleau, at Melun "she had a notion that some one had entered her carriage, and sat down opposite to her." The vision told her that he had known Professor Richet very well and had called him "Carlos," and was himself called "Tony" by him; and the apparition said, also, that he knew Fontainebleau very well and would accompany her on her walks. At intervals during the month of October the vision was often repeated and a number of details were supplied, calculated to prove the identity of the communicator. On carefully studying them it will be found that thirty-six of these are correct, eight are doubtful, two are partly correct, and five are incorrect. Some of these details concern matters unknown, as far as the Professor is aware, to any one except himself or his friend; one refers to something that he did after his friend's death. (When alone in the death chamber after Antoine B.'s decease he kissed the brow of the dead man. This was quite unknown to Mme. X.) Some incidents were either unknown or had been entirely forgotten by the Professor. Some of the five incorrect details are significant as evidence of the sincerity of Mme. X., since they are connected with matters which could easily have been ascertained by any one in communication with Antoine B.'s friends. (For Professor Richet, and the present writer, and others, to whom Mme. X. is personally known, such evidence of her integrity is superfluous; for those, however, who have not the privilege of personal acquaintance with her, these inaccuracies may have an evidential value and it is desirable that this value should be noted.) The "message" with which this episode closed was also very significant. It was to his wife, Mme. B., who had married again, and was as follows: "I will still watch over her even now; tell her no evil will ever befall her." On the day when this message was given Mme. B. was delivered of a still-born child.\* In concluding this record Professor Richet says. "The hypothesis of chance is absurd; the hypothesis of fraud is absurd; there remains but a third hypothesis, that of a phenomenon inexplicable by any of the existing data of our knowledge." He continues, "There is a certain impertinence in supposing that, in the Infinite Immensity of Worlds and Forces, man is the only force capable of thinking. It seems to me necessary to admit that there exist intelligent forces in nature other than man. . . . It is evident, however, that this hypothesis of intelligent forces ought not to be con-

\* In this connexion it is interesting to note that the facts which Mme. X. detailed, referred to events which had occurred twenty years previously.

founded with the hypothesis of human personalities surviving after death. These are two absolutely distinct hypotheses. Now I think that it is not the hypothesis of intelligent forces that is doubtful; what is extremely doubtful is that these forces can enter into communication with man. Moreover, why should they take the material appearance of a deceased human being and declare their identity with it? "We are disposed to endorse this question, and ask emphatically, *Why, indeed?*"

Since Professor Richet acknowledges that intelligent forces must exist, distinct from human organisms, it is not irrational to suppose that the force which caused this vision and communication was the intelligence of Antoine B., which had survived his physical body. The Professor himself seems to recognize the reasonableness of this opinion, for he says, "There is something that shocks us in the thought that, though the story told to Mme. X. be true, there was no Antoine"; and he adds that, though unconvinced as to what is the true explanation of the facts, this case "involves the whole problem of spiritism."

The other Frenchman to whose work in this connexion I desire to refer briefly is Dr. Maxwell, a friend of Professor Richet, and the author of a work, recently translated into English by L. I. Finch, and published during the course of 1905 under the title *Metapsychical Phenomena*. The preface to this work is written by Professor Richet, and the introduction to the English edition is by Sir Oliver Lodge. The latter describes Dr. Maxwell as an "earnest and indefatigable student of the phenomena for the investigation of which the Society for Psychical Research was constituted; and not only an earnest student, but a sane and competent observer, with rather special qualifications for the task. A gentleman of independent means, trained and practising as a lawyer at Bordeaux, Deputy Attorney-General, in fact, at the Court of Appeal, he supplemented his legal training by going through a full six years' medical curriculum, and graduated M.D., in order to pursue psycho-physiological studies with more freedom, and to be able to form a sounder and more instructed judgment on the strange phenomena which came under his notice." These words from Sir Oliver Lodge are sufficient to attest the competence of Dr. Maxwell as an investigator. He has been a psychical researcher for upwards of ten years, and, like Professor Richet, he has had the good fortune to meet with a singularly gifted "sensitive," who, as Sir Oliver Lodge states in his Introduction, is an "educated and interested friend . . . willing to give every assistance in his power towards the production and

elucidation of the unusual things which occur in his presence, and apparently through his agency."

In connexion with this sensitive, who bears the pseudonym of M. Meurice, and also with others, Dr. Maxwell has verified to his satisfaction the reality of many abnormal phenomena, such as the movement of objects without contact, and the various other strange facts, to express which Mr. Myers constructed his glossary of words, parakinesis, telekinesis, raps, crystal visions, etc., and, more recently, other phases of development have ensued of which an account has been added, in the English edition, to the original work.\*

Whilst we are endeavouring to estimate the value and bearing of scientific judgments on these matters, it is well to consider, What is the special aim of a scientific student as distinguished from those who are unscientific? To say, "the search for truth" would be misleading. All honest men claim to have this aim in view. Perhaps we may define the difference in this way. A mind with a scientific bent aims at co-ordinating *all* facts which come under observation, whereas those who lack the scientific qualities are content to recognize isolated facts without co-ordinating them; they feel no imperative need to synthesize them.

There are, of course, various degrees of scientific quality. Those who do not reckon themselves to be scientific at all do often, nevertheless, follow the scientific method just in so far as they relate the facts to one another which come under their notice. Their mistakes are due not so much to lack of the scientific quality as to the insufficiency of their data. A man with a trained scientific mind surveys a larger range of facts, and is on guard against "pre-constructing from too few factors his formula for the Sum of Things."

The typically unscientific mind treats facts as if they were pins in a pincushion, not stones in an edifice. This thing happens, and that thing happens, but there is, for an unscientific man, no reason why he should try to trace the two happenings to one common origin. The scientific mind, on the other hand, is constrained to try and do this. The temptation, if I may say so, which accompanies this impulse, is that of marshalling too many facts under one interpretative principle. If nine facts can be explained by one theory it seems inadmissible that the tenth

\* In 1905 Dr. Maxwell delivered an address before the Psychological Institute in Paris on "Les Phénomènes de Hantise," in which he claimed that these phenomena were sufficiently verified to merit the serious attention of the members of that Institute.

should prove refractory. It seems probable that further knowledge will cause it, too, to fall into rank : the probability becomes a suggestion difficult to withstand. It has to be corrected by another scientific quality, by the trained faculty which discerns differences. The lay mind easily overlooks slight differences, the scientific expert is always on the watch for them, and this discipline of watchful observation will put the really expert scientist on his guard against the constraining impulse to bring all facts under the interpretation of one hypothesis.

With regard to psychic phenomena, sometimes the co-ordinating faculty has shown a tendency to overbalance the distinguishing faculty.

Among a certain class of students the activities of the subliminal consciousness have been claimed as sufficient to account for a vast number of very divergent occurrences. This theory has been strained to breaking point in order to make it cover these various experiences. But a stage has been reached at which some leading scientific men, both in Europe and in America, recognize that the strain put upon such theories is excessive. They recognize that the facts are in revolt against this constraint, and that new factors must be introduced in order to account for them.

In England Sir Wm. Crookes asserted, before the British Association (1898), that "he had nothing to retract" in relation to the facts he had verified thirty years previously, facts which tended "to show that outside our scientific knowledge there exists a Force exercised by intelligences differing from our own." Professor Barrett has also claimed (*Proceedings*, Part xlviii.) that in his opinion "psychical research does show us that intelligences can exist in the unseen, and personality can survive the shock of death." Dr. Alfred Russel Wallace is well known as holding the same views. In America, Professor Wm. James, in connexion with Psychical Research, used the rather vague but suggestive expression, "For me, the bolt has fallen." And others, both here and on the Continent, have taken up a similar position.

And now, in France, we find Professor Richet renouncing altogether the notion that the phenomena under consideration have been accounted for by any scientifically authenticated theory. His words when addressing the Society for Psychical Research were as follows : "Jusqu'à présent nous ne connaissons que des phénomènes épars. Le lien qui les réunit nous échappe." And again, "Cette nouvelle théorie explicative des phénomènes, je ne la saurais pas, ne prévoyant même pas ce qu'elle peut être."

It may be argued, however, that it is a far cry from this

avowal of ignorance to the discovery of "something" which affords reason for supposing that "we survive death and that life has a moral meaning." So it may seem to the casual observer; for whilst ascertaining that received scientific theories do not suffice to explain the facts, Professor Richet treats the theory of the operation of discarnate intelligences as equally inadmissible. An examination of the whole case, however, shows that the position now taken by this distinguished French Professor may be really a big step towards the recognition of that "something" upon which so great issues depend.

For the facts which prove so intractable to the theories of subliminal activity, etc., are, many of them, facts which bear three distinctive qualities; they are intelligent phenomena, they appear to be purposeful, and they carry identifying evidence with them. Therefore, since all hitherto accepted theories are declared to be insufficient, the theory of the interference of intelligences, who were once men, has a right to be fully examined, for the very facts which remain unexplained by previous theories are those which suggest the reasonable possibility of the action of discarnate intelligences.

On this point Professor Richet expresses himself as follows, "Pour ma part, je l'avoue sans crainte, je ne vois *a priori* aucun motif scientifique pour repousser l'intervention d'êtres intelligents, autres que l'homme. L'hypothèse de puissances intellectuelles, évoluant autour de nous, dans cette immensité mystérieuse n'est ni invraisemblable, ni impossible. Mais ce n'est pas sur ce terrain de la possibilité ou de la vraisemblance qu'il faut placer la discussion. L'hypothèse est possible, assurément: il s'agit de savoir si elle est nécessaire. Or, jusqu'à présent cette nécessité ne me paraît pas évidente; car les limites de l'intelligence humaine, et des forces matérielles ou psychiques qu'elle dégage, n'ont pas été tracées encore."

This places very clearly before us the position which the Professor takes up. He recognizes that no known hypothesis can explain the facts, that the intervention of discarnate intelligences does not appear to be either impossible or improbable; but, at present, he is not convinced that there is conclusive evidence to prove such intervention, or to prove that these intelligences are human; and he thinks something may be discovered in the domain of physical or psychical forces which will explain the facts without having recourse to the hypothesis of this intervention.

But over against this speculative reason for rejecting the hypothesis of discarnate agencies must be set the fact (which he

acknowledges), that these inexplicable occurrences not only bear the tokens of intelligent, purposeful activity, but that they are repeatedly accompanied by indications which identify the intelligences purporting to communicate with some one who has died.

The position of the Professor is a negative one: the position of those who believe in discarnate action is positive. The former acknowledges that he has as yet no explanation of the facts, but believes that some adequate hypothesis may eventually be discovered; the latter claim that there is positive evidence that the discarnate intelligence theory fits the facts, and that these intelligences authenticate themselves by producing the kind of tests of identity which are requisite for the recognition of friends. Those who honestly assume the negative position and remain unconvinced are, of course, justified in so doing; conviction is, after all, a personal matter, and the personal equation enters largely as a determining factor into it. But the popular mind is not contented to allow for these variations in the effect of evidence, and is apt to conclude that, if an able and intelligent man remains unconvinced, this *proves* that the testimony is of a kind which ought not to be sufficient to convince any one; consequently, the superficial thinker underestimates the evidence, and sometimes dismisses it altogether as not worth serious consideration. Those who act thus show themselves to be really ignorant in relation to the subject, and therefore, of course, incapable of appreciating the trend of these discoveries and understanding their significance.

Whilst cautious reserve is displayed by those who adopt a negative attitude in relation to all hitherto suggested solutions of the problems that present themselves, they pursue their investigations diligently and persistently, with the result that a constantly increasing bulk of evidence is being amassed, the effect of which cannot fail eventually to be weighty, and will probably be far more permanent than it could have been, if the investigators had been less cautious and critical.

In conclusion I would suggest that it is a matter for satisfaction, that the researches inaugurated by British investigators should now be diligently pursued by our Celtic neighbours.

At the initial stage the subject was calculated to daunt all except the most doggedly persistent temperament. Any temperament that is quickly susceptible of discouragement could hardly have faced the obstacles which barred the way for the earliest pioneers. The Anglo-Saxon is noted for possessing this quality of dogged persistence, for refusing to be thwarted by unpropitious conditions. To these British virtues the Society for Psychical



Research may be said to owe the fact that it was not strangled at its birth. And we may be allowed to doubt whether the acuteness of the French intellect alone would have enabled the study to survive the odds that were against it when it was first inaugurated. That critical period is past, and it has gained a foothold among tolerated institutions. At the stage it has now reached, Psychical Research requires precisely the qualities which the French intellect supplies. And if the keen edge of that intellect and the *verve* and enthusiasm of the Celtic temperament are brought to bear upon the difficult problems and fascinating possibilities involved in this tremendous subject, this may result in considerably hastening the process by which "the puny notions that have been entertained concerning man and the universe" are already becoming profoundly and permanently enlarged.

It is a happy coincidence that one of the most prominent workers in the psychical research movement at the present time should be a naturalized Frenchman with a British name, and partly of British extraction, and that the sensitive who has been the means of enabling a French Professor to gain some of his most valued experiences is a British subject.

Of all the matters on which an "entente cordiale" is desirable there is surely none greater than this, a matter which more than any other involves the highest interests, not of England and France alone, but of the whole human race.

# THE MAGIC OF NUMBERS

BY EDWARD T. BENNETT

## PART II

### MATHEMATICAL.

READERS of a mathematical turn may be interested in a more abstract method of exhibiting the main features of the "Magic Squares" of the arithmetical series of numbers—1, 2, 3, 4, 5, 6, 7, 8, etc.

Let  $n$  represent any number. We will call it the root number of the square. The following formulæ will then be found to hold good :—

- $n$  = The Root Number.
- $n^2$  = The number of small squares forming the "Magic Square."
- $n^2 + 1$  = The sum of pairs of opposite numbers.
- $(n^2 + n) \div 2$  = The sum of the numbers in any one row.
- $(n^4 + n^2) \div 2$  = The sum of all the numbers in the square.
- $(n^2 + 1) \times 2$  = The sum of the numbers in each concentric circle.

$(n - 1) \times (n \div 2)$  = The "Leading Number" ("Die Leitzahl").

These seven formulæ hold good for both odd and even numbers.

When  $n$  is an odd number, the following also hold good :—

- $(n^2 + 1) \div 2$  = The centre number of the square.
- $(n^2 + 1) \div 2$  also = The number of *inside* numbers (in forming the square).
- $(n^2 - 1) \div 2$  = The number of *outside* numbers (in forming the square).

When  $n$  is an even number the first of these last three formulæ is substituted by :—

- $(n^2 + 1) \times 2$  = The sum of the four centre numbers of the square.

In this case also, the second and third of these last three formulæ have no application.

Purely mathematical considerations have probably been carried as far as most readers will care to follow, but there are other developments which may possess some practical interest. From what Hellenbach himself says, and from his references to antiquity, it might be supposed that the number of "Magic

Squares" which can conveniently be studied is very small. It would seem as if there were only nine "Magic Squares" consisting of 100 small squares or less, each with one single set of numbers, the "roots" being the arithmetical series 2-10. Beyond this the squares of successive numbers increase so rapidly as to become impracticable. Hellenbach tells us that one enthusiast worked out the Tetragrams up to that for 26! This involves 676 small squares and as many different numbers. If the number of

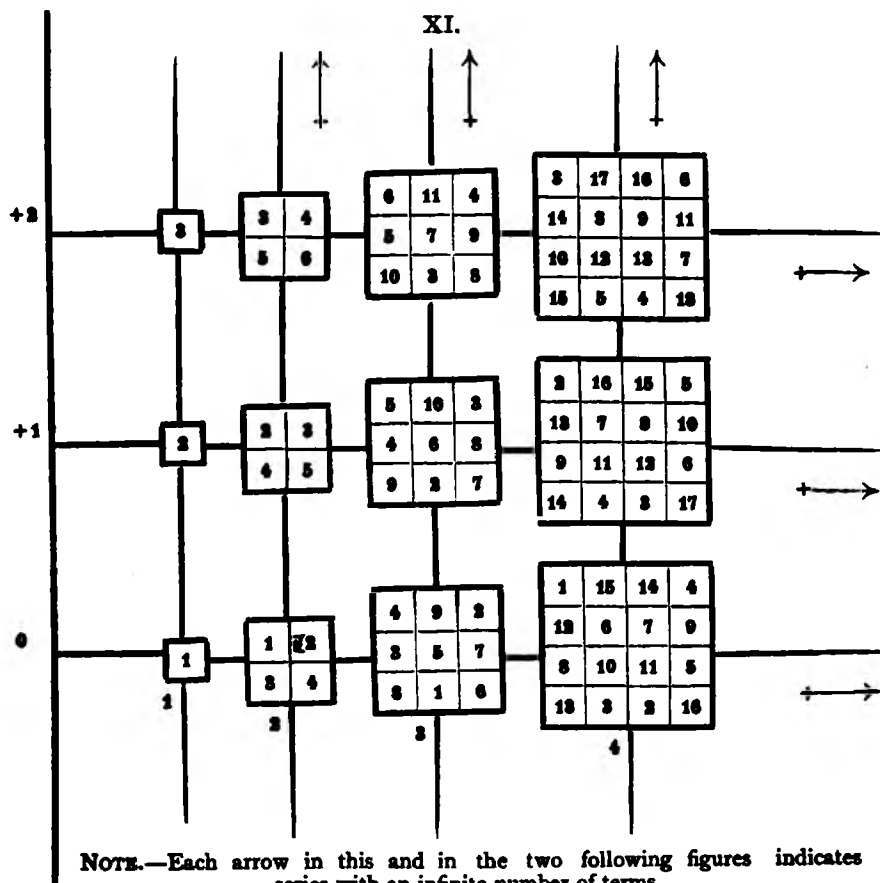

"Magic Squares" of reasonable dimensions were very few, the facilities for study would be small, and symbolic interpretation would be restricted to very small compass.

There is, however, no such limitation. The number of "Magic Squares," even of the smaller dimensions, is infinite. Let us take a base line starting from 0 and representing simple arithmetical succession. Along it we can construct our series of "Magic Squares." At 0 erect a vertical line with an ascending succession of numbers, as in Fig. XI. On each horizontal line above the

base line construct a series of squares and fill them with numbers as shown in the diagram, that is, adding one, everywhere. Series of "Magic Squares" are thus obtained which may be continued infinitely.

Again, instead of placing the arithmetical series of numbers along our base line, suppose we start with the "Magic Square" of 3, and multiply the number in each small square by 2, 3, 4, etc., we get a series of new "Magic Squares" along our base line

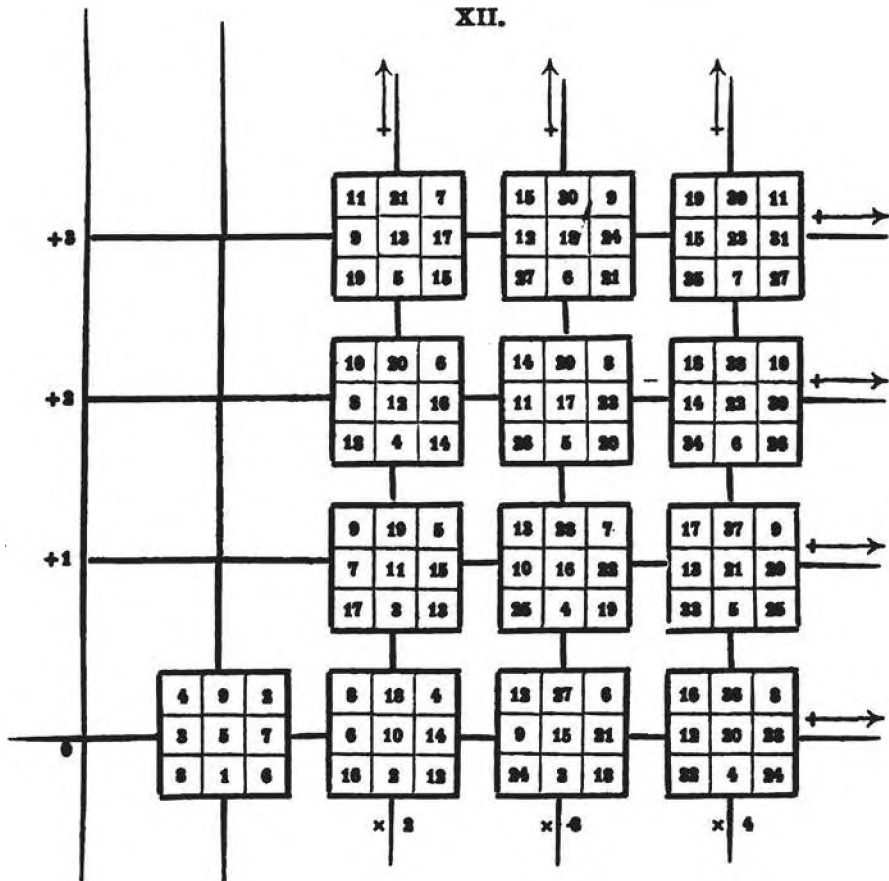

(Fig. XII.). If now we combine what we have done in Fig. XI. with this, we get new ascending series of squares, each series continuing of the same size, and possessing the same properties.

Again, if instead of taking longer steps, we take shorter ones along the base line, if we advance by tenths instead of whole numbers, and combine what we have done in Fig. XI., we get Fig. XIII. Eliminate the decimal point by multiplying all the numbers by ten, and we obtain a whole set of new series.

Both these last variations may be multiplied by taking other multiples and other fractions. The same processes may also be carried out with the original "Magic Squares" of other numbers. Thus without exceeding squares, of say 25 small squares, and without getting to large individual numbers, the number of "Magic Squares" which may be obtained is illimitable. Some curious repetitions of the same numbers will occur, but these are few and far between. With a little ingenuity, a square with any

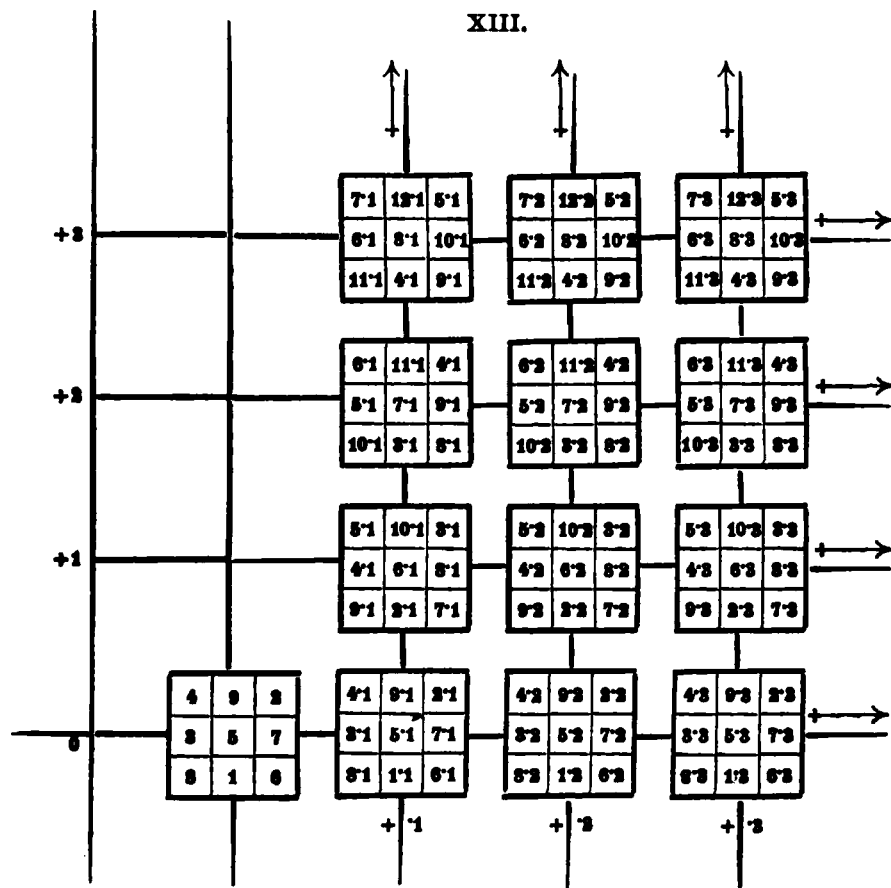

desired number or numbers in the centre, or with any desired number as the leading one (Leitzahl) may be obtained. The search for symbolism, and the discovery of what Hellenbach calls Periodicity, if it exists, would thus be greatly facilitated.

Beyond this again, if we imagine our horizontal and vertical lines extended in both directions, our zero point in Fig. XI. forming a centre, and if, instead of adding, we subtract along the two lines leftward and downward, we have a fourfold diagram, one

quarter only of which has been included in our previous considerations. An idea of it is given in Fig. XIV. In the quarter marked I we have to deal with the numbers of simple arithmetic only. In II and III we have a somewhat confusing mixture of + and - quantities, and in IV we have entered into a wholly negative region. But, in all four, an infinite number of series stretch out before us, all with an infinite number of terms, consisting of squares of numbers possessing the same principal features.

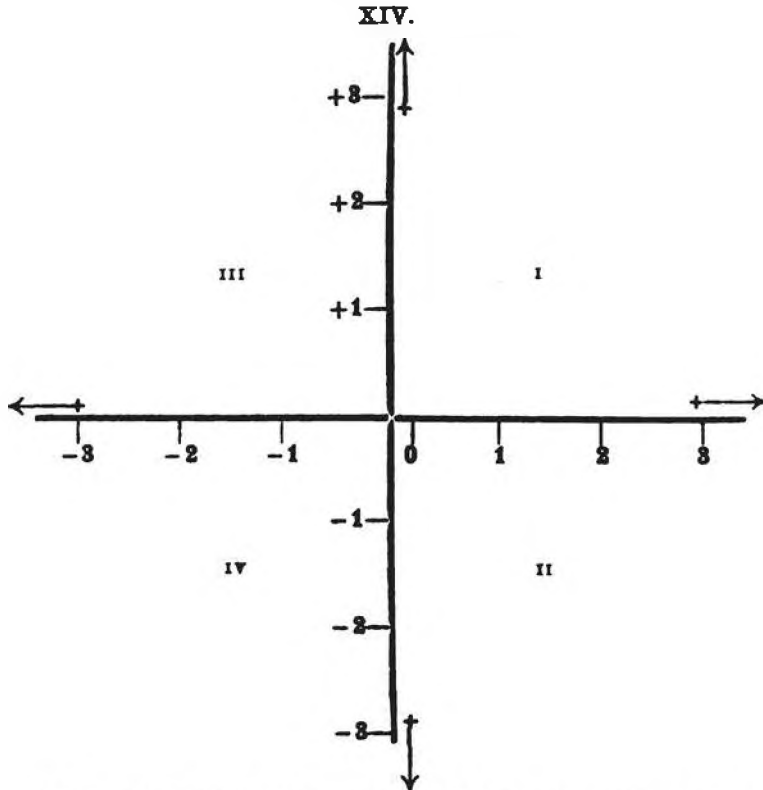

NOTE.—It would be easy, on a sheet of drawing-paper, with the help of the earlier Figures to construct a diagram with a portion of each quarter filled in, in detail.

We cannot, in this article, go further in these directions. The claim, however, seems almost to be justified, that the idea of number may thus be expanded from that of a one-dimensional infinite line, into that of a two-dimensional infinite surface. Baron Hellenbach in his book gives no indication that either he, or the ancients to whom he refers, were acquainted with these extensions of the construction of "Magic Squares," or that an infinite number of "Magic Squares" of moderate size can thus be constructed and studied with facility.

The literature of "Magic Squares" is scattered and not very accessible. In vol. xv. of the *Encyclopaedia Britannica* (ninth edit. 1883) is an article in which references are given to various writers on the subject, mostly ancient. References to several modern writers will be found in the Subject Catalogue in the British Museum. Major P. A. MacMahon, F.R.S., read a Paper before the Royal Society in 1904, in which he defines "Magic Squares," and describes their properties. An abstract of the Paper is given in the *Proceedings of the Society*. A small volume of thirty-two pages, entitled *Magic Squares*, by Thomas S. Barrett, a Fellow of the Royal Statistical Society, and a Member of the London Mathematical Society, was published in 1893. It contains much as to the different modes of their formation, and the varied properties they possess. But so far as I have been able to ascertain, nothing has been published as to their construction so simple as the preceding quotations from Hellenbach's book. And I have not met with any indications of the ways in which the number of such squares of small dimensions may be multiplied indefinitely, illustrated more clearly than by Figs. XI. to XIII.

Additional importance is now seen to be given to the "remarkable alternative" with which Hellenbach maintains we are confronted, and which is stated in his own words in the next paragraph.

#### THE LATER CHAPTERS.

It is quite impossible, within the limits of this article, even if it would be interesting and profitable—concerning which there would be very diverse opinions—to follow Baron Hellenbach through the remaining chapters of his book. Some of the titles are: "The Growth of Man and the Number Seven," "Apparent Fate," "The Periodic Oscillations of the Soul," "Phenomenal and Transcendental Measure of Time." All I can do is to quote, or give an abstract of, a few sentences, illustrating the tone of the writer's mind, and the drift of his arguments. In the Tetragram, or "Magic Square," he admits that he has not been able to find anything more than a graphic presentation of what he terms the Periodic System. He has not been able to gain anything beyond this, that it is a faithful expression of Periodicity. But, he says, "I am no learned Professor, who looks upon the limit of his own knowledge as the limit of all knowledge." And he maintains that we are face to face with "this remarkable alternative":—"Either, the ancients were acquainted with Periodicity—(but it is incom-

prehensible how they can have attained such knowledge in the then state of science)—*or*, they had no knowledge of it ; and in the latter case, the Tetragram must possess other properties, of which we are ignorant."

Pursuing this idea, Hellenbach says that the belief has been forced upon him that the number nine and its Tetragram were intimately connected with his own life. He devotes several pages in illustration of this. He says he is compelled to ask a series of questions :—" Could it be an accident " that such and such coincidences manifested themselves ? Then he remarks : each individual coincidence may have been accidental, but is it conceivable that all taken together were accidental ? After developing these ideas, he finally says :—" It is absurd to seek a horoscope in a Tetragram. But it is worthy of profound thought to consider the question—Is it possible that the manifold character of humanity is developed with a relationship to law, analogous to the manifold character of the development of all that which is perceived by our senses ? "

Hellenbach also considers that both historical and contemporary evidence absolutely demonstrate that a power of prevision into the future has a real existence. He adduces some of the evidence which is to him convincing, including a facsimile of a photograph of a Turkish MS., which seems to have a curious history.

Against facts of such a kind, he says, the opinions of academies of science are valueless. He maintains that there does exist a mode of observation which enables events to be known hours and years before their occurrence. And, on the other hand, that there is a power of perceiving what is past. That we cannot exercise such powers ordinarily, no more disproves their real existence than the inability of a Polynesian or of a dog to comprehend our mode of telegraphic communication disproves its reality. Various illustrations which Baron Hellenbach brings forward differ much in force and in importance. For instance, an invalid leaving his bed and going to the window, may again see what he saw a few minutes before on the road in front of him ; and by looking in the opposite direction he may see what he would have seen later from his bed. More suggestive are some remarks on the reflection in a mirror, which, as Hellenbach points out, is a mode of presenting a three-dimensional world in a two-dimensional form.

The following two paragraphs give the substance of the closing passages of the book :—

" While I consider speculations as to the course of human life



which are founded on the symbolism of the Tetragram vain and unfruitful, at least in most cases, the question—'Why am I in this world?' is by no means an idle one. I have already referred to Schopenhauer's dictum, that Fate may possess an objective correspondence, and a subjective conformability to that which exists. In my view, every man has the power of determining to work in both directions. The preponderance in different individuals may be in one direction, or it may be in the other.

"The labourer who works in a coal-mine, or throws up a dike, or cultivates the land, renders a service to the community. And if he cares for the welfare of his descendants, he will still find sufficient scope for the development of his character, and his life on this planet will not have been purposeless. The position of the more intelligent classes is surrounded with greater difficulties. In the office, in trade, on the Exchange, or as an Editor, the work is not always such as brings blessings with it. But, on the other hand, the opportunity exists, by the very complication and variety of the activity, to gain rich experiences. Worst off of all, is the rich man of whom the Scripture speaks, who finds it hard to enter the Kingdom of Heaven. Even such a man may lead a very useful life as a landed proprietor, or a merchant. But the chief occupation of these so-called happy mortals, or at least of the majority of them, is to devise means for killing time. Late going to bed, a late breakfast, some kind of exercise in order to get an appetite for a late dinner, then the theatre, then some hours of the night devoted to cards—how can anything that is worthy crystallize from such a round? How many fine talents of mind and spirit have I not seen perish in this way! It is only the changes of fate, and the lessons of experience, that enable man to find his way in the kingdom of symbolism, to discover the hidden meaning, and to act in accordance therewith."

As has been already remarked, it is no part of the purpose of this article to enter into the region of mere speculation. The object is to bring forward facts, and to allude to, or to indicate the possibility, that others may be discovered affording a basis for legitimate speculation, and for the scientific use of the imagination. It is conceivable that we may be thus led into fields of knowledge that we are as yet unacquainted with. Sound, light and colour, and to some extent the facts of chemistry also, bear certain analogous and numerical relationships to each other, which it is impossible to look upon as accidental, and as to which our knowledge is, to say the least, very imperfect.

## IN CONCLUSION.

The considerations which have engaged our attention lead to a realization of the truth of the four immortal lines in Alexander Pope's *Essay on Man*, in a more definite manner than possibly the poet himself ever consciously intended.

"All Nature is but Art unknown to thee."

The word Nature must be interpreted in the widest possible sense, as including all phenomena. The correspondence which we find existing between different classes of phenomena leads us to a belief in One great Artist.

"All Chance, Direction which thou canst not see."

Hellenbach calls special attention to his use of the phrase "Apparent Fate" ("*Die Scheinbare Fatum*"). He evidently believes that what we call Fate and Chance are the results of our limited point of view. He adduces various illustrations to show that this must almost certainly be so.

"All Discord, Harmony not understood."

This is more difficult to realize and to believe. But it is still more difficult to believe that Harmony and Discord are two realities of equal nature, and not that their actual relationship is akin to that between Light and Darkness. Light and Darkness, and Harmony and Discord in sound, are the results of differences in the rapidity of vibration.

In the fourth line we approach a higher kingdom which we shall not venture to enter :

"All partial Evil, universal Good."

These four lines carry us on to a magnificent conclusion, very far removed from a cold Pantheism. Modern Science and Philosophy are making more and more apparent every day, that :

"All are but parts of one Stupendous Whole,  
Whose Body Nature is, and God the Soul."

# WILLIAM BLAKE

BY EDWIN J. ELLIS

## PART II

IT is a commonplace that want of imagination leads to intolerance, rancour, severity, the grim spirit of censoriousness. It almost logically follows from Blake's identifying Christ with Imagination that he identifies Him with forgiveness. "The Spirit of Jesus is continual forgiveness of sin." (Preface to *Jerusalem*).

In one of the extra pages which belong to the poem called *Milton*, a page that though engraved was not issued with it (page 32), there is a passage in which Blake's Christianity is firmly incorporated into a portion of the Myth. To anyone unacquainted with the symbolic language in which this was written the passage would be without any sane significance. *Milton* was composed as a poem of twelve books which Blake afterwards cut down to two, this and other pages being cut out.

Then Hillel who is Lucifer replied over the Couch of Death  
And thus the Seven Angels instructed him and thus they converse :  
" We are not individuals but States, combinations of Individuals  
We were Angels of the Divine presence, and were Druids in Anandale,  
Compelled to combine into form by Satan the spectre of Albion  
Who made himself a god and destroyed the Human Form Divine  
But the Divine Humanity and Mercy gave us a Human Form  
Because we were combined in Freedom and Holy Brotherhood  
While those who combined by Satan's Tyranny, first in the blood of War  
And sacrifice and next in chains of imprisonment are shapeless Rocks  
Retaining only Satan's Mathematic, Length and Breadth and Height,  
Calling the Human Imagination, which is the Divine Vision and Fruition  
In which Man liveth continually, madness and blasphemy against  
Its own qualities which are servants of Humanity and not Gods or Lords,  
Distinguish therefore States from Individuals in those states,  
States change, but individuals never change nor cease.  
You cannot go to Eternal Death in that which can never die.  
Satan and Adam are states created into twenty-seven churches  
And thou, O Milton, art a state about to be created  
Called Eternal Annihilation, that none but the living shall  
Dare to enter, and they shall enter, triumphant over Death  
And Heil, and the Grave, states that are not, but ah ! seem to be.  
Judge then of thy own self ; thy eternal lineaments explore  
What is eternal, and what changeable, and what annihilable.  
The Imagination is not a State. It is Human Existence itself.

Affection, or Love becomes a state when divided from Imagination.  
 The Memory is a state and the Reason is a state  
 Created to be annihilated, and a new Ratio created.  
 Whatever can be created can be annihilated, Forms cannot ;  
 The oak is cut down by the axe, the lamb falls by the knife,  
 But their forms eternal exist for ever.

One seems to recognize the voice of Plato here, among others. Blake read everyone but did not quite agree with anyone. He was a red-headed Irishman. We cannot forget that if his grandfather had not married Ellen Blake after the birth, from an unknown mother, of his eldest son, and had he not then adopted her name, William Blake, the poet, and all his brothers would have been called O'Neil, the name that was their father's when a boy. None of the poet's family have a drop of Blake blood in them.

But the name of Blake has become the poet's by right of the celebrity he has given to it, and O'Neil need only be remembered when it helps us to understand the peculiarities of his character.

In youth Blake claimed that *desire* was good because it led to imagination, the source of all good. In later life he knew that it sometimes stands by itself. He then as frankly condemned it as taking time that ought to be devoted to art—"the service of the Lord." He says also :—

Man has no body distinct from his soul, for that called *body* is a portion of the soul discerned by the five senses, the chief inlets of the soul in this age.

For the cherub with his flaming sword is hereby commanded to leave his guard at the tree of life, and when he does the whole creation will be consumed and appear infinite and holy, whereas it now appears finite and corrupt.

This will come to pass by an improvement of sensual enjoyment.

For man has closed himself up till he sees all things through the narrow chinks of his cavern.

—*Marriage of Heaven and Hell.*

Beneath the bottoms of the graves, which is earth's central joint,  
 There is a place where contraries are equally true.

We are told to refrain from fleshly desires that we may lose no time from the work of the Lord. Every moment lost is a moment that cannot be redeemed.

I know of no other Christianity and no other gospel than the liberty both of body and mind to exercise the divine arts of imagination.

What is the life of man but art and science ? Is it meat and drink ?  
Is not the body more than rayment ? What is Mortality but the things  
relating to the body which dies ? What is immortality but the things  
relating to the spirit which lives eternally ? What is the joy of Heaven  
but improvement in the things of the spirit ? What are the pains of Hell  
but ignorance, bodily lust, idleness, and devastation of the things of the  
spirit ? And remember, he who despises and mocks a mental gift in  
another, calling it pride, selfishness, and sin, mocks Jesus, the giver of  
every mental gift.

\* \* \* \* \*

The Spirit of Jesus is continual forgiveness of sin. He who waits to  
be righteous before he enters the Saviour's Kingdom will never enter there.

\* \* \* \* \*

We who dwell on earth can do nothing of ourselves. Everything is  
conducted by spirits no less than digestion or sleep.

\* \* \* \* \*

Jesus replied, "Fear not Albion. Unless I die thou canst not live  
But if I die I shall arise again and thou with me.  
This is friendship and brotherhood. Without it man is not."

\* \* \* \* \*

Jesus said, "Thus do men in eternity  
One for another to put off by forgiveness every sin."

\* \* \* \* \*

And if God dieth not for man and giveth not himself  
Eternally for man, man could not exist, for man is love.  
As God is love. Every kindness done to another is a little death  
In the Divine Image, nor can man exist but by brotherhood.

—*Jerusalem.*

\* \* \* \* \*

It indeed appeared to Reason as if Desire was cast out, but the  
Devil's (energy's) account is that (imagination) the Messiah fell and  
formed a heaven of what he stole from the Abyss ("the abyss of the five  
senses"). This is shown in the gospel where he prays to the Father to  
send the comforter or Desire, that Reason may have ideas to build on.

—*Marriage of Heaven and Hell.*

\* \* \* \* \*

All life consists of these two, throwing off error and knaves from our  
company continually and receiving truth or wise men into our company  
continually. . . . Mental things are alone real. What is called corporeal  
nobody knows of. Its dwelling-place is a fallacy and its existence an  
imposture. Where is existence out of mind or thought ? Where is it,  
but in the mind of a fool ?

—*Description of Vision of the Last Judgment.*

\* \* \* \* \*

O holy Generation, image of Regeneration !  
O point of mutual forgiveness between enemies !  
Birthplace of the Lamb of God incomprehensible !  
The Dead despise and scorn thee and cast thee out as accursed.  
Seeing the Lamb of God in thy gardens and thy palaces  
Where they desire to place the abomination of desolation.

—*Jerusalem.*

He views \* \* \* \* all that has existed in the space of six thousand years  
 Permanent and not lost nor vanished, and every little act,  
 Word, work and wish that has existed all remaining still.

Shadowy to those that dwell not in them mere possibilities  
 But to those that enter into them they seem the only substances  
 For, everything exists, and not one sigh nor smile nor tear  
 One hair nor particle of dust, not one can pass away.

Yet he speaks elsewhere of tears, "tears of father, son, lover and husband," as being that which "if man ceases to behold he ceases to exist."

These scrappy quotations, arranged in no order here but such as tend to bring out their apparent mutual contradiction, are not unique utterances. They are all statements of beliefs that were held long and repeated in more or less similar words by Blake many times. They are an unconsciously painted portrait of the writer. They show him taking for granted that love and forgiveness are in no need of encouragement by religion, but that the claims of art need announcing, as people are apt not to understand that imagination, sympathy, forgiveness, visionary power are one quality viewed in different ways, and that to help one is to help all. The naivety of this in the utterances of a man who also said many times that he did not believe in the natural goodness of the human heart would be startling but that we know that he believed and depended on imagination, and held that all imagination was supernatural.

In his early book, the *Marriage of Heaven and Hell*, he acknowledges Swedenborg as his first awakener, but rebels against him as an insufficiently inspired prophet. In later life he spoke of him as the "strongest of men, Samson shorn by the churches." Certainly his own genius was worth ten times that of Swedenborg at its best. Blake has one hasty allusion to Jacob Behmen, and only one, and one to Paracelsus, in a sentence which does great injustice to Swedenborg. "Any man of mechanical talents may, from the writings of Paracelsus and Jacob Behmen, produce ten thousand volumes of equal value with Swedenborg's, and from those of Dante or Shakespeare an infinite number." He had probably not given either Paracelsus or Behmen much study. Shakespeare he did not read after he was grown up. Dante he only studied many years after writing this sentence. He wrote it in petulant anger with the monotonous and slender character of Swedenborg's imagination. Swedenborg was too nearly satisfied with the usual Christian idea of the nature of Christ,

which holds that His Divine part came from beyond the skies, and that His human part was only different from that of other men in being morally perfect, gifted with healing capacities, and capable of being dead for not more than three days, and afterwards of floating up to the sky—we do not know where or why. Blake was a constant and enthusiastic reader of the Bible and his imaginative temperament saw in many a phrase in the New Testament signs that its authors had very much larger ideas than these. To him Swedenborg's was too like the conception which has become crystallized among matter-of-fact people who try to be reverential without being imaginative, and make the cold failure of it which all ardent minds look on with consternation and pity. Blake's creed was recognized by Mr. Crabb Robinson as being closely related to the Christianity of the Gnostics. He went still further. In his poem, "Jerusalem," he once mentions the Smaragdine table of Hermes, and attributes to it a power over mental conceptions to draw them from the inner to the outer parts of mind, "draw down" is the phrase, for in his system of thought "what is above is within." He talks also of submission to "the rule of the numbers," and seems to have been aware of the Kabbala. But he did not attach great interest to anything but the Bible, and he read it continually, and read his own meanings into it, as into the laws of nature. His own imagination was more interesting to him than all.

"I must create a system or be enslaved by another man's," he says, and he never doubted either his power or his duty to create a system of thought which should interpret both experience and religion, and include philosophy and magic. Perhaps no one man has ever gone so near to realizing this superhuman ideal.

It is impossible to sum up Blake's Myth in a few lines without passing over in silence many episodes, and such silence is a sort of misrepresentation. The Myth's heroes, or gods are: The four main divisions of human mental experience, that are not like four slices of a cake cut in quarters, but are four personalities, the chiefs of a great crowd that inhabit us. They are always striving for mastery. Urthona is the name of the most material, and energy and darkness are his characteristics. He has a "vehicular form" which is a person called Los, who is "by mortals called Time," and who is really the Spirit of Prophecy. (One recognizes the doctrine of "vehicles" mingled with that of the divinity of Chronos.)

In the chief of all Blake's poems, "Vala," in which the rest

are included, so far as they can be, the whole Myth is described as an account of "Los,"

His fall into Division and his resurrection into Unity,  
His fall into the generation of decay and death, and his  
Regeneration by resurrection from the dead.

This poem "Vala," never even sorted into a proper order of pages in Blake's MS., was written at headlong pace, and is made up of lines of which over four hundred out of the few thousand that are in it were so visibly and obviously different from what the author thought he had written, that an attempt to restore the missing words and cut off the redundant was one that imposed itself on the editor. I did it timidly, badly, and unwillingly, and in notes indicated the original text in every case so that there might be no loss of record, and no disguise. The poem as it stands in the Quaritch edition has some few omissions and mistakes that I only discovered on going through the MS. again years later. They were supplied in the Grant Richards edition—that remains a mass of type, unpublished and useless since that publisher's bankruptcy. The poem is, I believe, far the greatest in the English, or I think, any other language. When a few hours of it fill the ear with its cadences Milton seems less buoyant and swift and Dante less melodious and enticing for some days after.

This "Los" Blake afterwards identified with himself :

I became One Man with him arising in my strength,  
It was too late now to recede. Los had entered into my soul.

Milton (page 20).

And on page 6 of *Jerusalem* the picture of Los is easily recognizable as that of Blake himself.

Urthona is generally mentioned last when the four divisions of humanity, the "four lives" or "four Zoas" are set out in order. The list then runs,—Urizen, Luvah, Tharmas, and Urthona. They have in the Myth's symbolism a correspondence with the divisions of London, and the discovery of this was the beginning, for the present writer, of the understanding of all Blake's symbolism, which had remained inexplicable to the genius and penetration of both the Rosetti brothers, and even of Mr. Swinburne, who in his fiery and enthralling volume on Blake shows that he had never even discovered that the four Zoas had a story at all, though without a knowledge of it all Blake must have seemed, what he thinks he finds some pages to be, "mere noise."



Urizen is mainly a reasoning and orderly and moral personage : he shrinks the imagination by refusing Desire that would be its proper source of " ideas to build on," and thus has attributes of the Creator. The Maker of Matter is really Satan the shrinker, and not even the Devil or Energizer. Blake perceiving this says (*Milton*, extra page 8) :—

Then Los and Enitharmon knew that Satan is Urizen.

Luvah is essentially the heart,—known to us as the elemental soil in which love is grown, whose beautiful flower, like that of other plants, is not found in the earth but in the air. Luvah, in action, is a spirit of the air.

Tharmas, symbolized in dark water, is the vegetative ruler,—growth kept down by doubt and sorrow.

Each has a female portion and a married life whose story is full of philosophic revelation as well as poetic charm,—but there is no space for it here. Each has a son, at one time his enemy.

The Zoahs change their positions and even their names, Luvah, who is at one time the Crucified One (*Jerusalem*, page 25, line 6), is at another " called Satan " (*Jerusalem*, page 49, line 68), but the changes are always full of meaning and are anything but mystification or confusion.

This passage contains a hint of how Blake made his message live in his symbols. He is uttering an exorcism of materialism, enemy of clairvoyant life :

Remove from Albion, far remove these terrible surfaces,  
They are beginning to form Heavens and Hells in immense  
Circles ;—the Hells for food to the Heavens, food of torment,  
Food of despair. They drink the condemned soul and rejoice  
In cruel holiness, in their Heavens of chastity and uncircumcision,  
Yet they are blameless and Iniquity must be imputed only  
To the State which they are entered into, that they may be delivered.  
Satan is the state of death and not a human existence,  
But Luvah is named Satan because he has entered into that State,—  
A world where man is by nature the enemy of Man.  
Because the Evil is Created into a State that Men  
May be delivered time after time, evermore. Amen.  
Learn therefore, O sisters, to distinguish the Eternal Human  
That walks about among the stones of fire in bliss and woe,  
Alternate from those states or worlds in which the spirit travels.  
This is the only means to Forgiveness of Enemies,  
Therefore remove from Albion these terrible surfaces.

*Jerusalem* (page 49).

H

The style of this solemn prose is far from the musical cadence of "Vala" written seven years earlier. The weight of responsibility, the feeling that he must get his doctrine out before poverty and labour struck him dumb, is the oppression that crushed out the music from this, Blake's later work. We must remember that he had to copy out every word *in reverse* as he printed from MS. written with varnish on the backs of zinc and copper engraving plates.

These fragments of his opinions are enough, not to describe his philosophy, but to show that his temperament built up his mind. Its poetic power is no longer in dispute, only the philosophic value is still doubted by many people; but the doubters are *invariably* found to have one quality in common,—ignorance of his work, which not one of them has ever read through with understanding, on account of the mental labour required by the richness of the symbolism, coupled with that needed to keep the occult perspective always before the eye, and the ordinary view of good and evil, wisdom and folly, safely folded up and left like the linen clothes in the Tomb.

Of "Vala," Blake's greatest poem, unprinted during his lifetime, a quotation must be given to show the style. The poem prints to 137 pages of thirty-four lines each. The following is part of a speech made by Enion, female of Tharmas, to Ahania, female of Urizen.

The words must be taken in the Blakean sense. For example, "Furrowed field"—married women. "Grave"—reserve of unused physical force. "Lamb of God"—inspiring imagination endowed through love with mediumistic and clairvoyant penetration. "Mystery"—moral code made for carnal restriction and invalid in imaginative life. "Tree"—the growth of its influence. In similar symbolism are used objects of nature, through which "Man" looks as indicating sense experiences through which life beyond the five senses breaks. "Orc"—bodily passion. "Urizen"—mere intellect. These are rough definitions, mere hints, not given for argument but to show the mental standpoint from which Blake measured the extension of good and evil, the lovely and the disgusting, the hopeful or horrible.

This passage is printed exactly as it stood in Blake's MS., being free from the slips and redundancies found in many other pages, though written, as was all the poem, at a tearing pace, and as usual with no attempt to make metrical emendations. The evidence for this biographical fact is not tradition or the author's statement, but the handwriting and appearance of the MS.

The verse is a fourteen-syllabled line, with a tendency to pause after the eighth. But the rule as to both length and pause is elastic.

The furrowed field replies to the grave, I hear her reply to me.  
Behold the time approaches when thou shalt be as a thing  
Forgotten. When one speaks of thee he will not be believed.  
When the man gently fades away in his immortality.  
When the mortal disappears in improved knowledge ; cast away  
The former things—so shall the mortal gently fade away,  
And so become invisible to those who still remain.  
Listen. I will tell thee what is done in the caverns of the grave :  
The Lamb of God has rent the veil of mystery, soon to return  
In clouds and fires around the rock, and thy mysterious tree.  
And as the seed waits eagerly, watching for its flower and fruit,  
Anxious its little soul looks out into the clear expanse ;  
To see if hungry winds are abroad with their invisible array,  
So Man looks out in tree and herb and fish and bird and beast,  
Collecting up the scattered portions of his immortal body  
Into the elemental forms of everything that grows.  
He tries the sullen north wind riding on its angry furrows,  
The sultry south when the sun rises, and the angry east  
When the sun sets, and the clods darken, and the cattle stand  
Drooping, and the birds hide in their silent nests, he stores his thoughts,  
As in storehouses in his memory. He regulates the forms  
Of all beneath and all above, and the gentle west  
Reposes where the sun's heat dwells. He rises to the sun  
And to the planets of the night, and to the stars that gild  
The zodiac, and the stars that sullen stand to north and south,  
He touches the remotest pole and in the centre weeps  
That Man should labour and sorrow and learn and forget and return  
To the dark valley whence he came and begin his labour anew.  
In pain he sighs, in pain he labours, and his universe  
Sorrowing in birds over the deep, or howling in the wolf  
Over the slain, and moaning in the cattle, and in the winds,  
And weeping over Orc and Urizen in clouds and dismal fires ;  
And in the cries of birth and in the groans of death his voice  
Is heard throughout the universe. Wherever a grass grows  
Or a leaf buds the Eternal Man is seen, is heard, is felt,  
And all his sorrows, till he re-assumes his ancient bliss.

Much of the poem is more dramatic and therefore, seemingly easier, is more symbolic and so more difficult. This is an ordinary example of the hot-hearted philosophic excitement with which even the mildest page is written.

## SOME LEAVES FROM THE NOTE BOOK OF A PSYCHICAL ENQUIRER

BY A. GOODRICH-FREER (MRS. H. H. SPOER)

(Continued)

[MR. ALEXANDER BREMNER writes, from Alyth in Perth on April 26, 1894, in regard to a story told him by a friend who was second engineer on board an Indian liner. He tells his story very briefly.]

“ He was going to relieve the chief engineer at the midnight watch, when he found him *staring into the engines and almost unconscious*. He took him upstairs on deck to put him to bed, and asked him what was wrong with him. The chief then told him he had seen the form of his sister, among the machinery, who told him she had died. They had seen his sister at Liverpool a fortnight before, when leaving England, and she was in perfect health, and they had had no letters from home since that time. When they got back to England in a few weeks time, they found that the lady had died of typhoid fever on the day he had seen the vision, making allowance for latitude. This happened east of Aden.”

The preceding stories may all be classified as thought transference from the dead or dying. I proceed now to some of those cases which seem to be of *local* origin. None are more common, none more perplexing. They are subjective in that they seem to depend upon the temperament of the percipient. They are visible only to a few ; I believe, in spite of some apparent evidence to the contrary, that they cannot be photographed. It is not evident why, given the right percipients, and the right local atmosphere, certain incidents should be perpetuated rather than others. The “rehearsal ghost,” who transmits his visualization of some tragedy or marked event, commends himself to one’s reason, but why should two monks preserve the fact that they went out for a walk ?

[An important, or at least interesting, detail in the following story is the passage in Dugdale referred to. An American

library is hardly the place in which to find a *Monasticon*, and I hope some one more happily placed, from the point of view of literature, will look it up. The dress seems like that of Franciscans and Carmelites. Are the two Orders likely to be in the same religious House ?]

Letter from Rev. J. A. Morrall, O.S.B., Downside, Bath—

“ In reply to your note received this morning, all I can say is that I believe Mrs. Reynolds, who is Mrs. Wickham’s maid and nurse, is a truthful, unimaginative, matter-of-fact, common-sense woman. I asked her what were the facts of the case, and she said that on Monday, November 2, she left the hall about 3 p.m. to take her usual exercise and fresh air, and went up the shrubbery that skirts the west wall of the garden, and joins the shrubbery that runs along the south side of the churchyard ; there is an outlet by a pathway to the church from the highroad, this pathway divides the parson’s field from the field of Farmer Hawkes. When near the junction of these pathways, Mrs. Reynolds saw, or thought she saw, walking in Mr. Hawkes’ field, as if they had come from the churchyard, two monks. One was in white, the other in brown ; one had a close-fitting hood, the other one ending in a point. They were not walking side by side, but one was a few yards in front of the other. They were walking with a firm, steady step. She was surprised at seeing them, as she had not heard of any monks being in the village, and as, from her position, she could not see their faces, she hurried on into another path alongside of them. But when she had reached a point where she thought she could see them they had disappeared. So convinced was she that she had seen real persons that the next morning she asked the Priest to say Mass for her intention. I tell the tale as it was told to me, and I pass it on to you.

“ (Signed) J. A. MORRALL.”

Father Morrall was for some years the priest at Wootton, so is interested in the place. The priest who is there now, Father MacCatee, questioned Mrs. Reynolds, and thinks her a reliable person. Also Dr. Agar, who is a physician at Henley-in-Arden, and has a private lunatic asylum, saw Mrs. Reynolds and thinks her a particularly sensible person, not likely to be influenced by any kind of excitement.

I find from Dugdale’s *Warwickshire*, that before the reformation, there had been monks at Wootton, and of the two orders

signified by the dress Mrs. Reynolds saw, the white and brown habits. She knew nothing of this, and there have been no monks there for more than 300 years.

Given me by Mr. Myers :—

“The following statement was dictated to me (partly in answer to questions) by Miss S——, a lady who does not wish her name to appear, and was then read over, corrected, and signed by her. The real names and addresses in the case have been given to me in confidence. A notable point in the narrative is that the ghost, as seen by Miss S——, should have exactly corresponded in appearance to the description given to her by others, *subsequently* to her own experience. I should add, that Miss S—— is a highly educated lady, who appeared to possess a calm judgment and strong nerves.

“*(Signed)* THOMAS BARKWORTH,  
“*Late Member of Council, S.P.R.*”

“*March 14, 1893.*”

“Somewhere about March, 1889, I was visiting at a country house in England. Previous to the experiences I am about to relate, I had heard nothing about the house being haunted, and was in no way expectant of anything of the kind.

“About a fortnight after my arrival I ran upstairs quickly to dress for dinner, being a little late. I had a candle in my hand, but the room was otherwise dark, with the exception of a little firelight. As I was in the open doorway, in the act of entering my room, I saw a female figure pass from a corner on the left side of the room to a window close by, a distance of about five or six feet. The figure was dressed in a dark gown, with a half train, and the dress was plainly visible, even to the folds in it. I saw the head, but the face was turned away from me. I felt no peculiar physical sensation of any kind, and at the moment took the figure for a servant, but on its disappearance behind the window curtains, I was driven to suppose that it must have been some sort of illusion, produced by the reflection of the fire on the polished surface of the cupboard, which stood in the corner. I did not mention the occurrence to anybody.

“About a week afterwards I again came up hurriedly to dress for dinner, as before, and saw exactly the same thing, but much more distinctly, including the outline of the head, but the face was turned away, as before. This time I felt some alarm, and mentioned the matter, as though in jest, to my host. I

said, 'How unkind of you to put me into a haunted room.' He did not answer, but looked significantly at his wife, who then said that she had asked if I were nervous and had been told I was not. She also added, that *the least* haunted room in the house had been given to me! Then she said, 'What you have seen, is a little nun, and she always stands at the cupboard in the corner, till some one enters and then she passes behind the window curtains.' (Of course, I had looked behind these on the disappearance of the figure). Her description corresponded in all respects to what I had seen."

[It is not, however, clear why a figure so dressed as to be mistaken for a servant should be called a nun.]

[The following story reached me through Mr. Myers. It is signed (Rev.) H. M. M. Evans, —— Rectory, Isle of Ely. March 11, 1890. The name of the house erased.]

"In the early spring of 1879, whilst living at M—— Rectory, I saw, on waking one morning in broad daylight, a female figure standing at the foot of my bed, and after a few seconds (as far as I can recollect) I saw her disappear through a door into an adjoining room. Some fortnight or three weeks, perhaps, after this had happened, I casually mentioned it to the rector's nephew, who had been living in the house some months previously. At first he rather evaded the conversation, but I at last ascertained from him that he had seen the same figure some time before I came into the house. The first time he saw it was between ten and eleven one morning, whilst he was reading in the dining-room, and I think he said he had seen her *certainly* twice, if not three times, after the first apparition. He had, however, promised his uncle not to mention this to me, in case I should have been frightened about it. I accordingly never mentioned the matter to my friends at M—— Rectory till some six or seven years afterwards, when they had come to live in quite another part of England, and on telling them about it, Mrs. B—— told me that a close connection of the person who was in the habit of appearing at the rectory lived in that neighbourhood; and in the course of conversation, whilst calling on the B——s, had, as a matter of fact, asked Mrs. B—— whether she had seen her relation whilst at M—— Rectory, and spoke of the appearance as quite an ordinary occurrence, so much so, that the servants were afraid to stop in the house.

“I should further add, that there was an old woman living in the village during the time I was there, who used to speak of the apparition as a fact, which she and her fellow-servants, whilst she lived at the rectory, had witnessed.”

[The following case is a good instance of the kind, in which one has no right to question the veracity or reasonableness of the narrator, but as to which time and space combine to make verification almost impossible. Mrs. Isabella E. Spencer, Tangiers, Morocco, wrote on December 17, 1889, to Mr. Myers a letter, from which I extract the following. Mr. Myers has endorsed the letter: “Answered, February 11, 1890. Corroborated.”]

She begins by telling an experience, not uncommon, of a place which has become familiar by repeated dreams, and relates how she described this place to a friend, the Rev. Edward Duncombe, apropos of an article by Forbes Winslow on *Brain Difficulties*—

“He appeared much interested—asked me to draw it, which I did. He then went into fits of laughter, and said, ‘That place is in this parish. [Mrs. Spencer had gone there house-hunting, lured by an advertisement.] Ask the first man you meet where it is.’ There it, in fact, was, but has since been burnt down. It was not the house she eventually took, but near it, and she describes her regret that she did not obey her intuition and leave the place, but the Rector laughed her out of it.

“Two servants, a governess, three children in the house; often visitors, my uncle (Mr. J. H.) and others. Occasionally, I fancied my chair was touched, and used to say to myself, ‘You are getting cold or nervous; go to bed.’

“The first occasion on which I really heard anything was at about 11 o’clock at night. I was sitting up to let in my uncle, who had gone to play chess with a neighbour. I was reading by the fireside, when I heard a tremendous bang at the door of the room, I thought; but I supposed my uncle had returned and banged at the window to make me hear. I ran out—nothing but moonlight. I ran up to the children—all asleep. I then went to the servants; they declared they had not moved. My uncle came back two hours after. I am not, and never was, nervous.

“The next day the parlourmaid, who was a very nice girl, came to me and said that she and the cook (who was a severe Methodist) did not believe in ghosts, but they were afraid to be alone a moment in the house, and as I had heard the row they



begged me to ask the governess about it, which I did. She said that her experiences were so awful that her mother had told her to leave me, but that her uncle, Colonel D——, had said she ought to be pleased and that she was now accustomed to it, and was only frightened when she first went to bed. There was, she said, a frightful noise of tearing up paper and her bed was pulled about, heavy tread of some one and swishings of a silk dress. I told her to be quiet and say nothing.

“ Before this, my children were in bed—two in one room and one in my room. They had a bellrope fastened to their bed to call me if they wanted me. One night it rang. I ran upstairs and they declared a *man* was in the house. They heard him ‘walk up the stairs and it was a robber.’ A dog who was under the bed kept growling furiously, but would not come out. I and the servants went over the whole house, cellars, larders—nothing. This was before I heard the crash.

“ An invalid friend came to visit me. She said she was too nervous to sleep alone—would I let the governess sleep in her room. I said ‘yes.’ I never had told her about the extraordinary noises. My uncle (now dead) and I were sitting before the fire at about 11, when he said, ‘My dear, there is some one ringing the bell.’ I replied, ‘Oh, the children,’ and ran upstairs—all asleep. I said ‘It is outside, will you come, as I do not like to open the door alone so late?’ *Nothing.* ‘It is a rat.’ He was rather a cross man and said, ‘A rat? *it was rung by the hand of a giant.*’ I went out to look at the bells; they had pendulums which swing for quarter of an hour at the least. *Nothing.*

“ My great desire was to see something. We used, I and a washerwoman, to go to the place where we heard sounds. One night I went to bed as usual. My child, who was about five or six, was in a bed alone. I had a very low bed, a chair by my bedside. I did not go to sleep, I am certain. Suddenly I became conscious there was some one in the room, and I saw distinctly a lady reclining in the chair. She turned towards me. I can see her now. Her hair was arranged in the early Victorian fashion—over her ears, pulled out, as I can just remember the fashion. She had bright staring blue eyes, and a long forehead and nose, and dark hair. I could not speak, but I got up on my elbow and as I did so she vanished. I then became rather nervous and had to light up the house and get up. Several times the children accused me of passing their room door without answering their calls, when I never had been near them. I

suggested the maid. 'No,' they said, 'we heard your silk dress sweeping along. (Trains were the fashion then.) The governess also saw the same face once.

"The children were left alone long before we heard these things, on Christmas Day, when all were at church. They ran out into the cold and said the upstairs bell had rung and that they saw some one in a red shawl at the window. The most extraordinary sounds were heard by every one. We got quite accustomed to it, and took no notice. After I left the house I went to Tower, near Llandudno, a place one might dream in, with a ghostly tower, uninhabited; there we never saw or heard anything—only rats on the stairs.

"One more thing. I was sitting late with a clergyman and a young friend before the fire in the drawing-room. We were all joking and laughing, when I saw some one come in by the door, and turned round, and said 'Lyddy,' thinking it was the maid. *No one. It was most distinct.* Two years after I left the house, I called on the curate, whom I had never known when I left, and when his wife and daughter came in, as I was leaving, they were, I saw, accompanied by a nice-looking lady. She smiled at me, but was not introduced. Next day I met the curate and asked who she was. He swore there was no one except his wife and daughters. That family had more extraordinary experiences than we had, and some persons were made ill by fright. He is dead. The Rev. R. M. Sharpe told me he had, after a while, decided to tell his visitors, beforehand, there were curious things about the house, and if they were afraid of any particular room he would advise them to sleep in another. One young lady was taken home ill, and the doctor said she was not to be questioned."

(*To be continued.*)

# THE ETHICS OF HYPNOTISM

BY NORA ALEXANDER

WHEN we see a man rushing headlong over a precipice, we do not hesitate about knocking him down or in any other way temporarily interfering with his freedom of action in order to save him, and it sounds quite simple and logical to say that when we see a man rushing headlong over a moral precipice we should behave in a similar way. But souls are more awkward things to handle than bodies, and minds are more delicate than muscles, so that most of us, when it comes to a question of interfering with a man's freedom of will, hesitate very considerably.

For instance, we are apt to look rather askance at hypnotism as a reforming agent, and maybe we are right. For although when we come to consider the matter with an attempt at impartiality, it would appear that the difference between hypnotic training and ordinary moral training is one of degree rather than of kind, since suggestion is at the root of both, yet the crux lies in the fact that in the latter case a man is free either to accept or reject the suggestion, whereas in the former he has either no choice at all, or very little. Perhaps the world's greatest debt to hypnotism lies in the profound and far-reaching truth which investigation into the limits of that choice has revealed. For the net result of numberless experiments performed, both by scientific bodies and individual investigators, may be taken to be this—that it is, if not always impossible, yet far more difficult, when in a state of hypnosis, to induce a normally moral man to sin than to turn a normally immoral man away from sin, or to express it differently, Good is a stronger power than Evil.

On the unimpeachable testimony of men like Liébault, Bernheim, Moll, Wetterstrand, and other recognized scientists too numerous to mention, we know that there exist in the world to-day men and women and children whose whole moral outlook has been altered for the better by a course of hypnotic training. In all these cases the ethical question of interference with free will has been solved either by the individuals themselves or their relatives, and no one else is in a position to express an opinion. But it is quite within the bounds of possibility that at no very distant date that same question may become one of vital public interest. And what then?

No one would suggest that morality and virtue should be systematically inculcated by hypnotism any more than that the

healthy person should be dosed with medicine. The normal individual is naturally best left to the normal processes of moral education. But what about the abnormal individual, the criminal, the mentally unbalanced, the morally unsound? How is he to be treated? Physical medicine may be all very well for physical ills (though some of us doubt even that), but how if the patient refuses to take it? Similarly how if he kicks against mental medicine? In the first case we may hold his nose and force him to swallow, and in the second we may hypnotise him and force him to believe. In other words, we know that hypnotism affords a means of administering a mental medicine that can often be administered in no other way, viz., the medicine of effective right suggestion, but we know too that it is a means implying the temporary subjection of one man's mind to another man's mind, and since we believe in the sanctity of mind, the problem instantly confronts us—"Are we justified in using such a means even for the conversion of a bad citizen into a good citizen?" which brings us back to the old problem, only lifted to an immaterial plane, of the rights of the individual, and how far for the good of the whole we are justified in disregarding them.

There is, I think, in the minds of many people a certain misapprehension as to how hypnotism "works" which is liable to produce a distinct and rather unfair bias in their judgment of it. I refer to the statement one often hears made that moral reformations effected by hypnotic treatment must be intrinsically worthless, since only that goodness which springs from within is possessed of any real value. But it must not be forgotten that a man cannot *be* good unless he first *wills* to be so. Willing must always precede action. On the physical plane, for instance, we cannot perform so simple an action as the lifting of a limb until the brain, at the instigation of the will, has first given the order. Similarly, on the mental plane, a man must first want, or will, to be good, before his moral muscles, to to speak, will carry out the order. Now the work of a hypnotist is not to make a man good in spite of himself, but merely to arouse in him a desire to be good, and then leave him to work out that desire for himself. He does not interfere with will itself, as will; he merely changes its direction.

Neither hypnotic suggestion nor moral education can create goodness. It is there already in every man, implanted in the soul from the beginning. Both systems can only by the application of stimuli cause the faculty of will to work in such a way as to bring that goodness to the surface. But—are all stimuli legitimate?

## REVIEWS

THE TWICE BORN. By a late Associate of the S.P.R.  
London : Philip Wellby, 6, Henrietta Street, W.C.

IF all fancy were fact, the world would take comfort to itself on the reading of this remarkable narrative. No longer would it concern itself with the problems of a declining population, the vexations of hereditary transmission, or the doubts which are raised by the advocates of natural selection ; but would concern itself wholly with the question of mental and spiritual culture, and the mysteries attaching to the generation of spiritual children. Stella Riches is engaged to Reggie Brooks, and both are affected sincerely with the study of psychism and elective affinities in the human species. They receive instruction of a professed teacher of transcendental physics, and in course of time they marry. They have learned from Boehme and other mystical writers enough of the laws controlling the generation of the eidolon to enable them to try a great experiment. Children are born, first of all, into the Children's Land from the union of minds acting as centres of positive and negative psychic energy. Only afterwards are they drawn down into physical birth, and then not always into the family of those who are their soul-parents. Guy and Stella are such Soul-children, the direct offspring of Stella and Reginald Brooks. In process of time they take birth in the family of Colonel Palmer and his wife, quartered in India. They meet their original parents during a visit of the Palmers to England, and evince such spontaneous affection for Mrs. Brooks and her husband as to excite the jealousy of their natural mother. Eventually, the Palmers are killed in the earthquake at Lahore, whither they have returned ; and it is then found that Mrs. Palmer, having a dread premonition of impending death, has dedicated her children to the tender care of the Brookses. In the course of the narrative it is revealed that these soul-children are of a grade of intelligence and moral rectitude quite ethereal, and not only have they a conscious memory of the Land from which they have emanated, but also are endowed with psychic faculties, which enable them to return thither in sleep at night, and to bring back fresh impressions and recollections. Thus, unconsciously, they more than fill the lives of the otherwise childless

people who were responsible for their first or psychic birth, and thus, too, is Wisdom justified of her children.

SCRUTATOR.

OCCULT CHEMISTRY. By Annie Besant. The Theosophical Publishing Society, London and Benares.

THIS is the third of a series of reprints from the journals of the Theosophical Society, in this case from *Lucifer* of November, 1895. The date is of no consequence, for, as the Publisher's Note informs us, the issue containing the article is out of print, and it is felt that the present reprint is timely, modern scientific investigations being found to curiously confirm the conclusions arrived at in regard to the constitution of the chemical atom from occult methods of research. The author remarks that there is a wealth of speculation but a poverty of observation in regard to both the atom and the nature of ether—for lack of any means of observation; but appeal being made to the higher activities of the senses shows that, owing to normal sensory imitations, there are vast numbers of vibrations, still physical in character, which leave the normal senses wholly unaffected.

“The keener and more delicate senses of the astral body are latent, for the most part, in men of our race, and are therefore not available for general use. Yet they afford instruments for observation on the higher level of the physical plane, and bring under direct ken objects which, from their minuteness or subtlety, escape ordinary vision.” It is not stated through whose astral senses the observations here put on record were received, but it is thought well that the credit should be given to members of the Theosophical Society for a first statement. It is said that “the word ether covers four substates, as distinct from each other as are solids, liquids and gases, and that all chemical elements have their four etheric substates, the highest being common to all and consisting of the ultimate physical atoms to which all elements are finally reducible.”

A very graphic description of the constitution of the complex gaseous atom as perceived by the astral vision is given and is further elucidated by a diagram of the process of resolution or breaking up of the gaseous atom into its ultimate physical or prime etheric constituents, it being seen in effect that an atom of oxygen contains 290 ultimate atoms, and one of nitrogen 261 of these ultimate physical atoms. The contained bodies being in each case 18, this number is used as a divisor, and the following

approximations to the atomic weights are derived : Oxygen,  $\frac{290}{18}$  or 16.11 etc. ; Nitrogen,  $\frac{261}{18}$ , or 14.5. These are sufficiently near the latest statements of science to be interesting, but in order to be of real importance the results would need to be much closer, unless, indeed, science should see fit to review its observations and revise its figures. Another astral observation of interest is that "as weight numbers (atomic weights) increased, there was a corresponding increase in the number of bodies discerned within the chemical atom ; thus gold showed 47 contained bodies, etc." Prof. J. J. Thomson, of Cambridge, has suggested that "atoms are clusters of hundreds and perhaps thousands of ultimate particles which are all alike," and says that "it is probable that the atom will be found to be a complex aggregate of one or more ultimate substances," which statements are in singular agreement with the observations made from astral observation ten years previously. The pamphlet will be read with interest by all who are concerned with the recondite problems of the physicist.

SCRUTATOR.

**SELF-SYNTHESIS : A Means to Perpetual Life.** By Cornwell Round. London : Simpkin, Marshall, Hamilton, Kent & Co.

THIS work by all canons of fair criticism must be relegated to the category of works which are synthetical of efforts which have preceded it. It is not in itself fairly to be regarded as original with the author, except in so far as the process of collation, application and synthesis is concerned. No new principle is involved. It is nevertheless a most vitally interesting contribution to the literature of the New Thought movement, for which possibly it may have been designed. The author asks the almost time-worn question : "Why die ?" He shows that the idea of the certainty of death at or near a certain age is the result of racial hypnosis. We do not wear out as machines do. The period of greatest activity is the period of greatest development and growth. The law of inertia is favourable to the persistence of the individual life, which, until acted upon by an outside influence, should by that law persist. This outside influence is heredity of ideas. In answer to the question as to how the idea of death became rooted in the human mind, the author says

that it arose from tribal practices, which incited to the early destruction of the weak and ailing, and authorized the extermination of the aged and increpit. People began to look upon death as a consequence of living, and the idea became crystallized in the brain. The people resigned themselves to the inevitable.

But this is all wrong now. Nature has finished her work of selection. The fittest have survived. They should continue, as individuals, to survive. Mankind must learn how to remain much longer in its existing incarnation, so that experience, often so dearly bought, may not be dissipated by premature death. Abandon the hereditary idea that death is inevitable, and the organic changes which make for senility will not supervene, or at least will be almost indefinitely postponed. The idea is great, but, unfortunately, like perpetual motion and some few other Utopian ideas, it is difficult to realize. No provision is made against accidents, no consideration made for the important fact that until we come into the world of our own conscious freewill it is hardly likely that we shall depart hence under like impulse.

Mr. Cornwell Round has a deep understanding of symbology, and he uses both symbol and analogue to the fullest possible extent in illustration of his principles. He has it that in man there are three states of consciousness: the Subjective, the Individual, and the Objective. In this he subscribes to the tripartite division of the human constitution recognized by the Gnostics, among whom we may include St. Paul. Man is subject to suggestion of an impelling order from both the Subjective and Objective regions of the mind. At present he is negative to the Objective. He has to become positive to it and negative to the Subjective. Finally, he has to synthesize all experience in the Individual. He is then Master of Life and Death, as of himself and all his faculties. He has effected the Magnum Opus—the Great At-one-ment. He is in all things god-like. I am confident that this book will have a large sale. It is lucid and synthetic. It suits the needs of the age.

SCRUTATOR.



## PERIODICAL LITERATURE

*The Word* (New York) for June contains an interesting exposition of Japanese Buddhism, by T. Suzuki, Monk of the Nicheren Sect. He lays great emphasis on the essential oneness of all things, and of all states of being, and some of his teachings may be applied to the elucidation of the more abstruse problems of Christianity as set forth in the Gospels. For instance—

To imagine that the man known to us by history was the true Buddha is entirely false. What, then, was the true Buddha? The true Buddha is that Sakyamuni who from time immemorial has been sufficiently enlightened to know the underlying sameness of all things, and the identity of his own person with the external world; he is that Buddha who identifies a pure act of thought with all existences in time and space; he is that state of mind in which truth and the intellect, the perceived and the perceiver, cease to be two and are recognized [as One in essence. If this is the case with Sakyamuni it cannot be otherwise with the people generally. Just as he regards all living things as his own children, so may each individual man do likewise. The Buddha and the people are, in fact, one and the same; there is neither difference nor distinction between them.

In the same way the inhabited world is identical with the paradise where all Buddhas live. This world, full of evils as it appears to our eyes, is perceived by the Buddha to be a peaceful and happy realm inhabited by beings of a high spiritual order. It is all a matter of perception.

When enlightenment is attained, the whole world is found to be equally glorious and splendid. When we have developed this Buddha-wisdom, we shall perceive the real nature of this world of evils, and the glory of that eternal reality which underlies the world of outward sense; we shall proclaim the identity of the phenomenal world with the glorious underlying reality, point out the way to Buddhahood, open the path to salvation, and, above all, we shall be brought to realize that each and all may become Buddhas here and now. This is the mission of the Nicheren sect.

Writing in the same magazine on "Experience and Memory," Elizabeth Wetterer divides memory into three aspects: remembrance, recollection, and reminiscence. We *remember* when we have been prompted by some external impression which recalls something which was not in our mind at the time. Under this heading the writer refers to ancestral memory, or what we call instinct; that which causes a little chicken just out of the egg to shrink and cower at the approach of its ancestral enemy, the

hawk. "Man has lost much of his instinct by reasoning, but the faculty of remembrance is shown in man by habits." *Recollection* is the voluntary recalling of some previous experience by an effort of will, a faculty not possessed by animals. Our power of recalling an impression depends upon the force with which it was originally impressed upon our minds. The third division of memory, the one called *reminiscence*, is what is called in philosophy "soul-memory."

This is the ability to go direct to the storehouse in which is indelibly engraved the memory, not of the one life alone, but of countless lives, and which is impervious to sleep and death and time. It is the momentary flash of this memory which inspires poets, painters, musicians, sculptors, philosophers, and all genius.

The tablets on which these memories are engraven are not those of the physical brain, but, according to the theosophical views of the writer, "the astral light," which keeps "an unmutated record of all that was, that is, or that ever will be."

An interesting contribution on the same subject of memories which do not appear to be recollections of personal experience, is afforded by the Rev. Forbes Phillips in an article on "Ancestral Memory" in the *Nineteenth Century and After* for June. Mr. Phillips takes the view that the first of Mrs. Wetterer's categories is the place for classifying reminiscences of places or events with which we have never been normally acquainted. He thinks that they are handed down to us from some ancestor who had the experiences which we at times mysteriously recall. When visiting Tivoli for the first time, Mr. Phillips had a curious experience—

The whole place and countryside were as familiar as my own parish. I found myself struggling with a torrent of words, describing what it was like in the olden days. I had read nothing of Tivoli, and seen no views; yet here I was acting as guide and historian to a party of friends who concluded that I had made a special study of the place; then the vision in my mind began to fade. I stopped like a man who has forgotten his part, and I could say no more. It was as if a mosaic had dropped to pieces.

At Leatherhead, where he was a stranger, Mr. Phillips volunteered to guide a friend, also a stranger, to the place where a Roman road formerly ran; he found it, and, he says, "there was the feeling that I had been on that road before, riding, and that I had worn armour." A brother clergyman had similar experiences: he took Mr. Phillips and showed him over a Roman camp near Mr. Phillips' own village of Gorleston, and remarked

that in the old days they used to plant a mast in a socket on the top of a ruined tower, and sling men up in baskets to pick off the ancient Gorlestonians. They examined the remains of the tower, and found the socket thus strangely indicated. But perhaps Mr. Phillips goes too far when he supposes that the experiences of dying can be transmitted as hereditary memory, and when he infers that ghosts only appear to those whose ancestors had met the living originals. We must not seek to apply a single cut-and-dried theory to every individual instance.

An article by Alice C. Ames, in *Broad Views* for July, entitled, "Concerning Mental Healing," gives some interesting hints, derived from experience, as to the method of pursuing this "fascinating study." After "wasting a good deal of mesmeric force" on a servant whom Mrs. Ames nevertheless succeeded in curing, she says—

I learnt later that the hypnotic subject requires nothing more fatiguing from the operator than suggestion, and generally gives quicker and more successful results than the mesmeric patient, mesmerism being a depleting process, demanding physical health and patience in those who exercise it for the benefit of others.

Servants, as a rule, make good subjects, because they are accustomed to yield implicit obedience to injunctions which come to them "enveloped in the glamour of a superior personality." But the suggestion must be a correct one. Mrs. Ames cured her parlourmaid of toothache, and the housemaid came to her for the same thing. But in this case the treatment did no good; closer questioning revealed the fact that it was neuralgia, not the aching of any particular tooth, from which she was suffering. So suggestions were given that the housemaid was not to have neuralgia, with the result that for two years she was perfectly free from it.

The same review makes three incursions into the field of old-time occultism, referring, in different articles, to Dumas *père*, to the Comte de St.-Germain, and to the manifestations in the Wesley family, which are called "premature," because no system of intelligent communication by means of raps had as yet been proposed.

*Modern Astrology* for July contains a long article on the horoscope of Dr. Richard Garnett, showing how precisely the astrological indications corresponded with his character and bent of mind. Dr. Garnett had expressed misgivings as to the effect of certain "directions" for this year, and the Editor shows that

by taking mean time instead of astronomical time as the measure, they coincide with the very day of his death.

The *Hibbert Journal* for July contains an article by Sir Oliver Lodge on "First Principles of Faith," in which religious teaching on a scientific basis is cast in the form of a brief catechism. Writing on "Signs and Wonders in Divine Guidance," Miss Caroline E. Stephen refers to the change of attitude towards "the supernatural," and, following Professor James, discusses the validity of mysterious communications in regard to religion.

Spontaneous personal intimations include not only coincidences, but the less historical and verifiable cases of presentiments and premonitions, of knowledge without "outward information," of mysterious promptings to perform certain acts or visit certain places, of apparitions and visions and dreams and voices.

She refers to the rich store of such occurrences in the records of the religious Society of Friends, and though "each instance of a personal intimation must of course be judged on its merits," her own belief is "that it is right and reasonable for us to expect that we should be able to hold some immediate communication with the Father of our Spirits," and to look for guidance from this source; but she denies that the claim to be under divine guidance involves a claim to infallibility; individual impulse needs to be tested and corrected by collective judgment.

In the same review Mr. Robert H. Smith, formerly a Professor at Tokyo, writes on "Japanese Character and its probable influence outside Japan." He alludes to the belief of every Japanese "that he lives amidst, and is continually guided by, the spirits of his ancestors," and says—

The death of the national soul would be an unspeakable calamity, and the individual lives of its present visible embodiments must be readily sacrificed to maintain it in vigorous life. The dying individual's spirit simply passes from the visible to the invisible realm, and what happier *dénouement* is possible to a life necessarily spent in building up to greater maturity the grand old spirit of Japan than a sudden passing over to the glorious undying ghost world?

*The Annals of Psychical Science* for July gives an interesting description, written by Signor Ernesto Bozzano, the well-known psychic investigator, of the work of Professor Cesare Lombroso, the celebrated criminal anthropologist, of Turin, with regard to psychical research, to which he has for several years devoted much attention.

# PSYCHOMETRIC DELINEATIONS AND ANSWERS TO ENQUIRERS

BY THE "OCCULT REVIEW" PSYCHOMETRIST

## DELINEATION (DR. S. A.).

This hair is dead and has, I should say, been cut some years.

I sense, *at first*, trouble and great anxiety at the thought of either saying good-bye to some one or at the thought of some separation. This subject is intense. They feel deeply and love and trouble seem to go together. Conditions are not good, but as I come through the very difficult first conditions I come to a wider and brighter condition; what was narrow and anxious at first becomes broad and happy with an intense desire to watch over a loved one from whom I am separated for a time, and this sense of watchfulness and care is the dominant note in this hair. Dead as it is, the spirit of the owner is very strong and would make me think they inhabited this earth still.

A man and a young girl are very much bound up with this person's life. The girl seems near them now, but the man is at some distance.

I get a very lovable personality, but I sense always the sorrow and disappointment of the wearer, though it is passed now.

## EROS.

1st question.—Help can be given to the lost friend by sending strong, true helpful thoughts through to them and by living this life as the friend would have wished. Nothing hinders so much as useless fretting; great good can be done and much help given by accepting cheerfully a separation of this kind. When it is possible, a few quiet moments of communion will help both.

2nd.—I consider the change is marriage. I get no other explanation of it, but I do not consider it will take place for some time, may be two or three years hence.

## PATIENCE.

The lady wearing this glove is not happy. Influences in her life prevent her living her life in the way she would wish and one influence causes her much unhappiness. There is another influence in her life, but I do not feel that these two lives meet or come any nearer than the present, the obstacles between them could not be overcome. I feel them nearer in the past, and am confident the future will bring separation.

I think much depends on the wearer of this glove. She must decide for herself and another, and she *can* do this. Life has made many demands on her and she has done her duty bravely and well. This separation will be a great trial, but it is right, and she will eventually find comfort in this, for she has a strong, true character, and in herself she knows her present hesitation is wrong, both to herself and another.

She should remember in doing right herself she helps another to do right also, and this thought should make her strong.

This is written by a man. He is quick and active and a good-natured man. At the time of writing this he is somewhat depressed and unhappy. He is writing to a woman he is very fond of, but is sad because he knows their present relations cannot continue. He feels they must part, and yet he cannot bring himself to suggest it and leaves it to the woman, for he knows what it means to both. He is a strong man, yet in this matter I find him weak and uncertain. If it were only himself to suffer, he would have given it all up some time ago, but he dreads the effect of this parting on the woman, and he is afraid she will not understand him. For some time the position has been getting very difficult, and the sooner it is ended the better for both, because it will grow worse and be still more impossible next year.

I get a feeling of success for this man, and he should turn his attention to his profession, for it seems there is work waiting for him.

#### DELINEATION (MARY ROW).

This hair is cut from the head of a very nervous young man who is subject to nerve fits. He lives in dread of an attack and often makes himself worse from this dread. He should try to conquer this; he can do more for himself than any doctor. There may be a tendency to asthma, but the true disease is nerves, which he alone can overcome. When he feels the attack coming on, he should resist it with all his strength. He will gradually lessen the force of the attack and each attack overcome will strengthen him.

#### ARGEMONE.

These letters are written by a young woman who is very anxious to make the most of the change and holiday she is having. She is married, but her husband is not with her when she writes these letters. She is devoted to her son, who has not been very strong, but he is better and will gain strength each year now. This woman is somewhat undecided. She feels her place is with her husband who is abroad, but she dreads foreign life and fears for her health, but his profession will keep him from living in England for some years, and there is no chance of a settled home life for these two people, unless she goes abroad, and I do not feel it will hurt her or her child as much as she thinks, and it will certainly be better for both in the future, if this sacrifice is made now.

#### MARMADUKE.

This handkerchief is used by a man who is rather depressed and unhappy. Things have gone very hardly with him and he is feeling desperate; he is anxious to get on and yet there is no real success for him, and the influences of his life at present are against him.

He will make a change, but he must wait for the opportunity, and the right moment has not yet arrived. Next year he comes into contact with a man who will be very useful to him. He is a man who works, but he is successful. Through this man he takes up some new work—outdoor work, I think, in Canada—and I then get a steady rise in position and a much happier condition altogether.

He should try and overcome the present depression and should make up his mind to make the best of his present surroundings ; the work and people are very uncongenial, but being discontented in himself only makes them more so.

I should like a little more perseverance with more determination to overcome the present obstacles. I think there would be a brighter condition.

THORA.

My first impression from your glove is that great changes are coming into your life within the next month or two, but I do not think the change is caused by marriage. It seems to me that you are about to leave your present abode, and I think you will go to the house of a lady and you seem to be with her and her husband some time. After that I find you in another house, and this time with another lady. You appear to settle with her for some time and I should be surprised if you married next year, in fact, I think marriage for you is some two or three years ahead.

DESORMAIS.

*1st Question :* Shall I have any children ?

*Answer :* Yes ; since I feel the influence of children very strongly in your life, though I think you will be married some years before your first child is born. I think you will have two.

*2nd Question :* What will be the outcome of my present financial difficulties ?

*Answer :* The present conditions are very difficult, but they are not your own making. Influences and circumstances have been against you, and you are at the moment going through a very bad time. You should have been more careful two years ago, and then you would have had a freer hand now, but the present tightness will become easier about November, and then I get things improving. Try in the future to keep things more in your own hands, follow your own instincts and don't let others influence you so much.

You are naturally quick and clever, but you soon lose confidence in yourself. Try to act always as if you are acting for others, then you will do better for yourself, for I do not find you nervous or uncertain when you are managing for others, but you lose your nerve when you do things for yourself.

At present you are depressed and very disappointed. You must overcome this feeling, for it weakens you more than you think, and people who are very interested in you are beginning to think you are not the man they thought you. This is very foolish and you must show them that your ability is as good as it ever was, and though circumstances have been against you lately, you will have pluck enough to fight through this bad trial.

You have some very good influences about you and many who will be ready to help you. Don't shut yourself up too much, you don't need pity, but you need not refuse sympathy, and you have been getting rather nervous and irritable lately.

Success is for you, but you have a few months' fight before you, then the road is clear and I do not find such a bad time again. Do try and cheer up.

## CORRESPONDENCE

*[The name and address of the writer, not necessarily for publication, is required as evidence of bona fides, and must in every case accompany correspondence sent for insertion in the pages of the OCCULT REVIEW.—ED.]*

### DIVINATION BY CARDS.

*To the Editor of the OCCULT REVIEW.*

DEAR SIR,—I have read with interest in the OCCULT REVIEW records of various forms of divination, and should like to give something of my own experience.

Some twelve years ago my sister and I learned the meanings of a few cards—a very few—and by word of mouth, from a woman we knew; and though I do not intend to give any of them here, I should like to impress on those interested, that rules for fortune-telling by cards given in magazines and papers are, to my mind, no use, and certainly not like the method we use.

Like many young girls, we enjoyed having our fortunes told, but were as sceptical on the point as most people; and thought it a bit of fun. Fun we enjoyed, however, and this soon became a study. For five years we shuffled cards at home and read them for ourselves; then we began reading for our friends; and now, though of course not making a profession of it, we are consulted again and again by interested and anxious acquaintances, with wonderful, and I may add, weird results.

It is a study one can pursue day after day, always finding more to learn. What is it? Ah, I should dearly like to know. Something peculiar to the reader I think there must be. I know nothing of clairvoyance, and yet am persuaded that I have something of the sort about me in a small way, for sometimes I cannot read cards at all, or, at any rate, only with great effort. At other times the meaning comes to my brain in flashes, and the prophecies I then make, though most improbable, and often causing smiles, nearly always come true.

“Coincidence—pure coincidence,” some kind sceptics say, “because everything you say does not come true.” Perhaps not; but is it not rather the ignorance of the translator? For instance, give a student some French to construe, and though he may know the words, unless he has learned the grammar, what a garbled affair his translation will be. And often it may be so



with card-reading : so many cards mean different things, according to the cards surrounding them ; and only practice and keen observation and memory will surmount this difficulty.

I remember one day not being able to tell the meaning of a card in a particular group. I was going a journey that same morning, but it told nothing about actual travelling, and I resolved to watch and observe, confident it would happen, and being rather inclined to think it was something unpleasant with the weather. Whilst changing trains at a small station, the rain came down heavily, and I was soon wet and uncomfortable. I remembered the group of cards, and have never seen them in a like position since without experiencing rain either for myself or client.

I gave a friend a reading last year, as she wished to know if an intended journey to London would be pleasant. I told her I thought so, but it would rain badly when she went. It was then lovely summer weather. The morning for her journey came, and with it torrents of rain—it simply swilled the streets—and she was compelled to take a cab in order to reach the train. Three years ago we took to cycling, and whilst learning soon found the card which meant bicycle. I put this to show how one can learn to translate in one's own way, and I think there must be a certain telepathy of the mind or thought-reading associated with it, because it is easier to read for a believer than a sceptic. As a rule a sceptic's cards are unreadable, whilst some can—as I often say—be read off like a book.

Character reading, too, can be successfully told by cards—the mind often showing in the shuffled bits of cardboard—how I do not in the least profess to know.

Much care should be taken to read clearly before speaking. Much harm may be done by ignorance, in the same way as it often is by professing palmists. A clear understanding is needed, and then a boldness to speak. I always smile when asked how I make it all up ? An ignorant and foolish question surely—How could I make it all up ? The vital question surely is—How comes the story into the cards ? By what agency are they placed each in their allotted places, able to be read clearly and sensibly ? Like other mysteries, we do not know. That they *are* so placed and can be read by those who know how to read I am certain from my own experience.

I am,

Yours faithfully,

G. B.

## "MAGIC" NUMBERS IN CHEMISTRY.

*To the Editor of the OCCULT REVIEW.*

DEAR SIR,—The article on the "Magic of Numbers" by Mr. Bennett in the July issue of the OCCULT REVIEW raises some very interesting points connected with the relation of numbers in sound and light, and it is pointed out that colours and musical sounds depend on certain harmonies in the vibrations of the ether and air respectively.

The author mentions Baron Hellenbach's hypothesis of a possible periodic system in chemistry.

It is interesting to observe in this connexion that the vibrations of musical notes increase in number per second as each higher note in the scale is struck, and that every *seventh* note possesses a remarkable resemblance to the *seventh* below and above it in the scale, both in tone and the number of vibrations per second.

A parallel, more or less exact in its resemblance, exists in chemistry.

It is found that if the elements are written in the order of their increasing atomic weights (excluding the argon family of inert gases) every *seventh* resembles that before and after it remarkably, both numerically and in its chemical and certain physical properties. This was called by Newland in 1867 the *law of octaves*.

The modern form of this theory (elaborated, but practically unaltered otherwise) is so exact and reliable that it is possible to predict minutely the nature and atomic weight of undiscovered elements, and this was successfully done in the case of gallium, discovered in 1875.

Yours faithfully,

C. DE CREYÉ.

## MAGICAL METATHESIS.

*To the Editor of the OCCULT REVIEW.*

DEAR SIR,—I have been much interested in the arguments adduced by Dr. Franz Hartmann in his article bearing the above title, and, in the course of my reading, have wondered to what extent, if at all, information of this order is likely to find credence in a matter-of-fact age like this of ours. What stands for "matter-of-fact" commonsense, however, is more often than not an excuse for pronounced superficiality, incapacity and ignorance.

Few people are aware, for instance, that magical metathesis is going on continuously in obedience to the fundamental laws of (1) the conservation of energy and (2) the correlation of forces, in such form and to such extent as to pass for matter-of-fact when assuredly it is matter of supremest mystery. Among the more uncommon forms of metathesis which have come under my observation, I may mention that involved in the resolution of sulphuric acid by electrical action, and the electrification of carbon which results in a species of metabolism.

In the first of these cases, it is possible to hold either the acid or the soda base in a state of suspension and transmit them on an electrical current from one position to another. Thus, if three vessels be taken, in the first being dilute sulphuric acid, in the second dilute syrup of violets, and in the third pure water; the first and second vessels being connected by strands of wet blotting paper or rag strips, and the second and third similarly connected; the terminals of a battery are placed in the first and third of these vessels; the result being that, in a short time, the acid and its soda base are found to have parted company and one of them to have been transmitted into the vessel which contained pure water. The terminals being reversed, transmission of the other body is found to have been effected. In either case, the dilute syrup of violets remains *unaffected*. Normally, the action of an acid would be to change its colour to red, while an alkali would change it to blue.

The question raised by this experiment is: What was the chemical nature of the body transmitted while it was in a state of suspension during the process of metathesis? The answer seems to be along the lines suggested by Dr. Hartmann, namely, that the molecular vibration of the body was raised by the electrical action to a point whereat it was temporarily changed, in chemical nature, from an acid or an alkali to a somewhat else.

Similarly, it is reported by Sir David Brewster, in his *Cream of Scientific Knowledge*, that, on an occasion of stormy weather, a chimney was found to have been clean swept by an electric current, the carbon particles being carried across the room, through a covered ottoman, and neatly deposited, in a thick layer, upon some clean linen within. The question arises: In what condition was the soot when it passed through the solid side of the ottoman? It was undoubtedly in a state of suspension, probably also of high fusion, and the molecular vibration must have been enormously greater than that of either pure carbon or any of the ammonium compounds which are usually

present in coal-soot. What prevents, therefore, that even organic bodies, may, under certain conditions, suffer a transmutation of their particles, that they may be carried or translated by some of the great etheric currents which encircle the earth, and finally reintegrated and deposited at some distant spot, and that with greater celerity than could be effected by any conceivable means of mechanical locomotion ?

I do not propose to bestride any witch's broomstick for the purpose of sweeping cobwebs off the sky, but I trust I have said enough to suggest that there may be a natural metathesis which, in our present state of bliss, cannot be regarded as anything but magical.

Yours, etc.,

W. GORN OLD.

### OCCULT REVIEW PSYCHOMETRIST.

THE following offer is made for the present month, and may, or may not, be continued. Any reader desiring to have questions answered by the OCCULT REVIEW Psychometrist, must cut out, and send up, not less than four coupons such as that given below, and dispatch the copies from which they are cut to friends who may possibly be interested in the subject-matter of the magazine. Each querent will be entitled to ask not more than two questions. Any reader desirous of having his, or her, character and general conditions psychically diagnosed, will be required to send up not less than eight coupons, and double space will be allotted to these diagnoses. Readers who desire to avail themselves of this offer should send either a glove or tie, or piece of ribbon that they have worn constantly, or failing this an ordinary letter. Whatever is sent must be done up in a separate parcel, marked with the name or assumed name of the inquirer, and sealed. This separate parcel should be sent under the same cover as the letter containing the inquiry and the necessary coupons. Care must be taken that the article or letter is kept away from contact with other influences previous to its dispatch, as these tend to confuse the Psychometrist. The articles thus sent will not be returned.

**PSYCHO COUPON.**

*August, 1906.*